

### Mighty Mix

The Mighty Mix injection mixing controller is a stand-alone microprocessor based controller for radiant heating and/or boiler reset applications. The application provides programming capabilities for a wide range of reset options via a 4 simple button keypad. Simple programming and display of current data is done on a back lit LCD Information Center display.



### Overview

The Mighty Mix controller is a compact, microcontroller-based motor speed control for single phase AC pumps when used in injection mixing applications. It controls the pump speed to maintain water temperature at a fixed setpoint or a variable setpoint based on outdoor reset. The Mighty Mix can also be used on a modulating output such as a proportional valve.

### Features

- Low cost injection mixing control for hydronic or radiant heating
- Simple configuration and setpoint adjustment
- Digital LCD back lit display for temperatures and settings
- LCD status indicators
- Boiler return temperature protection for noncondensing boilers
- Alarm output for sensor faults and over temperature conditions
- Test mode for pump speed control and temperature sensors
- Temperature Sensor Inputs: 10KOhm thermistor compatible with iWorX series sensors
- Can be used to control a modulating boiler, injection mixing pump, proportional valve or on/pff boiler
- Relay output to control an indirect water heater pump or other auxiliary high temperature load
- Optional room temperature sensor input for automatic adjustment of the reset curve based on indoor temperature feedback
- No batteries are required to retain program settings

### Copyright Notice

This document copyright © 2005, Innovex Technologies.

The confidential information contained in this document is provided solely for use by Innovex Technologies employees, licensees, and system owners, and is not to be released to, or reproduced for, anyone else. Neither is it to be used for reproduction of this control system or any of its components.

All specifications are nominal and may change as design improvements occur. Innovex Technologies shall not be liable for damages resulting from misapplication or misuse of its products.



Innovex Technologies  
511 Braddock Avenue  
Turtle Creek, PA 15145  
[www.innovextechnologies.com](http://www.innovextechnologies.com)

iWorX is a trademark of Innovex Technologies  
LON, LonWORKS, & LONMARK are trademarks of Echelon Corporation

## Application Description

The Mighty Mix controller provides pump control for injection mixing pumps used in radiant heating systems. The output of the pump is controlled by looking at four sensors; outside air temperature (OAT), boiler supply reset temperature (RES), boiler return temperature (BLR), and indoor room temperature (RM). The outside air temperature is used to derive a control temperature for the boiler supply. The controller then keeps the supply temperature at a constant as long as the boiler return temperature is above a minimum value and the room temperature is being controlled. The indoor room sensor also can generate a call for heat as well as an external call for heat contact closure. The controller linearly controls the mixing pump while providing contact closures for secondary pumps and heat demand output to the boiler. A 0-10VDC control signal output is also provided for control of modulating boilers. An Auxilliary input is provided to generate a boiler contact closure and auxilliary output contact closure. During Auxilliary mode the Secondary Pump Output is left in its previous state.

## Inputs

### Power Supply

The Mighty Mix is powered by 95-130VAC, 50/60Hz (optional: extended range to 265 VAC). No switches or settings are required for voltage or frequency selection. External transformer can be sized to accomodate any load requirements.

### Heat Demand Input

The Mighty Mix includes a dry contact input for heat demand. This activates the reset circuit on a call for heating.

### Aux Demand Input

The Mighty Mix includes a dry contact input for auxiliary demand such as an indirect water heater. In this mode, the reset is bypassed and the auxiliary demand returns the boiler to its' higher setpoint temperature. Once the auxiliary input is satisfied, the injection pump is re-activated according to the reset schedule.

### Sensors

Four sensor inputs are provided on the Mighty Mix. Three of these sensors are provided with the Mighty Mix. These are 10KOhm Type III thermistors. These sensors are also compatible with the Innovex iWorX-Radiant series controllers (Precon Type III, Automation Components type AN, or equivalent can also be used). The NTC thermistor is approximately 10kOhm @ 25C (77F), 1kOhm@ 93C (200F), and 100kOhm@-24C (-12F). Accuracy is to be +2F with up to 100' of wire

### Supply Temperature Sensor

An input is provided for a supply temperature sensor for feedback of the controlled water temperature. The temperature measurement range required is 32 to 221F.

### Return Temperature Sensor

A sensor input is provided for feedback of the boiler return temperature. The range is the same as the supply sensor.

### Outdoor temperature Sensor

An input is also provided for an outdoor temperature sensor. the control reads the outdoor temperature in a range of-60 to 120F .

### Indoor Room Temperature Control and Feedback Sensor

An optional room sensor can be used with the Mighty Mix to provide a zone or room temperature control with indoor feedback. This is useful, espacially in the zone of greatest demand to automatically adjust the reset schedule based on actual room feedback. A TRW1, TRW2, TRW3, or TRW4 room sensor can be used for this purpose. The room temperature setting is adjusted via the Mighty Mix keypad.

## Outputs

### Injection Pump Motor

The Mighty Mix is capable of controlling the speed of a permanent split capacitor (PSC) or shaded pole motor, with no switches or settings required. The triac output has a rating of 3.0A. The power supplied to the motor is determined by the temperature control loop algorithm.

### Zone Pump Motor

A line voltage dry contact output with a rating of 1/6hp is provided for a secondary pump. This pump is activated on a call for heat, or can be set for constant circulation during the heating season and disabled once the warm weather shutdown temperature is reached by selecting "continuous pump".

### Auxiliary Pump Motor

A line voltage dry contact output with a rating of 1/6hp is provided for a secondary pump. This pump is activated on a call for heat, or can be set for constant circulation during the heating season and disabled once the warm weather shutdown temperature is reached by selecting "continuous pump".

### Heat Demand Output

A low voltage dry contact is required for a heat demand output to a boiler control. The output has a class 2 pilot duty rating of at least 25VA.

### Modulating Output

This output provides a 0-10V output signal for a modulating valve or modulated boiler output.

## Connections

All line voltage connections are made to clearly marked terminal block connections located on the right of the printed circuit board. Terminals accept 12 AWG wire with 300V insulation; Wire leads should be stripped 1/2" with the jacket pulled back 1/8".

A terminal block with all low voltage connection is also provided. This terminal block is located on the left hand side of the printed circuit board. The terminals accept 18-24V AWG wire and terminal designations are indicated in the printed circuit board.

## Terminal Block Connections

**Sens Com:** Common for sensors

**OAT:** Input for the sensor that is monitoring the outside air temperature.

**RES:** Input for the sensor that is monitoring the loop temperature being reset

**RM:** Input for the room temperature sensor. If not used, the control will default to 70 degrees F input.

**BLR:** Input for the sensor that is attached to the boiler return. When this temperature drops below the programmed value the mixing pump and secondary pump will be shut down. If this sensor is not used, the control will default to 205 degree F. The alarm will flash but the control will work properly.

**Sens Com:** Common for sensors

Heat Demand Input: Input to signal a demand

**Aux Demand Input:** Input for an auxillary device to signal a heat demand to the system. When this set of contacts is closed, the Boiler contacts on the control will close. If an auxillary device is not connected to the Heat Demand inputs, the Mighty Mix will control the Boiler contacts when the room temperature drops below the prograded set point.

24 VAC Input: Input from class 2 transformer

**Boiler Contacts:** Contacts close upon heat demand.

**0-10 VDC:** Output for modulating device.

## Line Voltage Terminal Blocks

**TB1:** Supply Power Line (120 VAC)

**TB2:** Injection Mixing Pump

**TB3:** Secondary Loop Pump

**TB4:** Aux. Output (indirect Waterheater or other loads)

## Display & Indicators

An alphanumeric LCD display is provided. Each temperature and setting has a unique identifier (letters or numbers) to identify the current display. The display shows the secondary loop temperature whenever no buttons have been pressed for a minute. The other temperatures and status values may be displayed by pressing the “up” and “down” buttons; pressing any button then returns to the sensor list.

The display indicates the status of the following items:

- Heat demand
- Injection pump output ( percent output or flash rate proportional to pump speed)
- Minimum return protection
- Warm weather shutdown
- Sensor fault and other fault indication

The display and all indicators are visible without removing the front cover.



## Settings

All settings listed in Table 2 are entered and stored using a simple 4 button key pad. Pressing the “Up” and “Down” buttons simultaneously for 3 seconds enters the setup mode, which allows the settings to be changed. The setting names may be selected by scrolling up or down through the list. Pressing “Select” again returns to the list. Pressing and holding it for 3 seconds returns to the temperature display. The values are stored in non-volatile memory (no battery required to retain settings)..

**Table 1: Settings**

Setting	Range	Default	Description
Temperature Units (Degrees)	DegF, DegC	DegF	Units for all temperature displays
Room Temperature (Room)			Room Temperature Setpoint
Outdoor Reset Low (OAT Low)	-60 to 50F (-51 to 10C)	-4F (-20C)	Outside air temperature (cold) at or below which the water temperature is at its highest
Outdoor Reset High (OAT high)	51 to 80F (11 to 27 C)	68F (20C)	Outside air temperature (warm) at or above which the water temperature is at its lowest
Outdoor cutoff temperature	41 to 122F (5 to 50C)	68F (20C)	Temperature at which the setpoint is at a minimum and above which heating is disabled
Maximum supply temperature (RES High)	68 to 203F (20 to 95C)	149F (65C)	Setpoint when at or below the outdoor design temperature
Minimum supply temperature (RES Low)	68 to 203F (20 to 95C)	95F (35C)	Setpoint when at the outdoor cutoff temperature
Minimum return temperature (Blr PRO)	5 to 185F (-15 to 85 C)	5F (-15C)	Minimum temperature allowed at the return sensor during demand
Continuous secondary circ. (2nd Pump)	Auto, On	Auto	If On, the secondary circulation is run continuously when cold outside, if set to Auto the pump runs when there is a demand
Pump exercising (2nd Pump)	Normal, Exercising	Normal	If set to Exercising, the pumps are run for 15 seconds each after a week being idle.

## Control Sequence

### Power-up

All outputs must remain off until valid inputs are obtained. The display then shows the current supply temperature. The setpoint is determined by the reset line established by the outdoor and supply temperature endpoint settings.

### Test Mode

If all three buttons are depressed for 5 seconds, the injection pump output is set to full output, then gradually reduced to its minimum value in about 5 seconds, where it remains until any button is pressed or power cycled.

### Fault detection and handling

A temperature sensor reading greater than 245F (<500Ohm) or less the -60F (>500kOhm) is considered a fault. If at any time the supply sensor has a fault, the outputs are disabled and the fault is indicated. If the sensor returns to a valid reading for at least one minute, the fault is indicated, but normal control continues without return temperature protection. If the outdoor temperature sensor has a fault, an outdoor temperature of 32F is assumed, and normal control continues while the fault is indicated.

A high limit alarm for the secondary loop occurs when the supply temperature exceeds the setpoint by more than 20F for more than one minute, or by 40F at any time. All outputs are disabled while this fault is indicated. The fault is cleared when the temperature drops to within 5F of the setpoint.

### Temperature Display

The PSC-3 can display temperature in degrees F or C, this option is set by entering the program mode. Once set the PSC-3 will save the setting during power failures. All temperatures referenced below are in the default degrees F.

### Heat Demand

There are two sources of call for heat for the PSC-3. The first is the Heat Demand Contacts, whenever there is a close switch across these contacts the PSC-3 will respond to the heat demand. The second is by using a Room Sensor (RM -4) and the Room set point set in the Programming Mode. Once the room temperature drops 2 degrees below the set point the internal heat demand is activated. The heat demand will stay active until the room temperature reaches the set point. Either of these heat demand inputs must be active for 2 seconds in order to take effect. Once activated the heat demand will stay active for a minimum time of 5 seconds. If the outdoor temperature is above the OAT Hi setting the heat demand is ignored and the Main display shows Warm. The temperature must drop to 5 degrees below the OAT Hi to clear the warm weather shutdown.

Once a valid demand for heat is activated the PSC-3 will turn on the pump contact (If 2<sup>nd</sup> Pump is set to ON it will be on whenever the PSC-3 is not in warm weather shutdown. If it is in Auto it will turn on at this point) and start to modulate the variable speed pump output. The PSC-3 will take all the sensor readings and program settings to calculate the correct modulating output.

### Current Reset Temperature

First the Outside Air Temperature is measured and a loop control temperature is determined according to the Loop Control Temperature Calculation graph below.

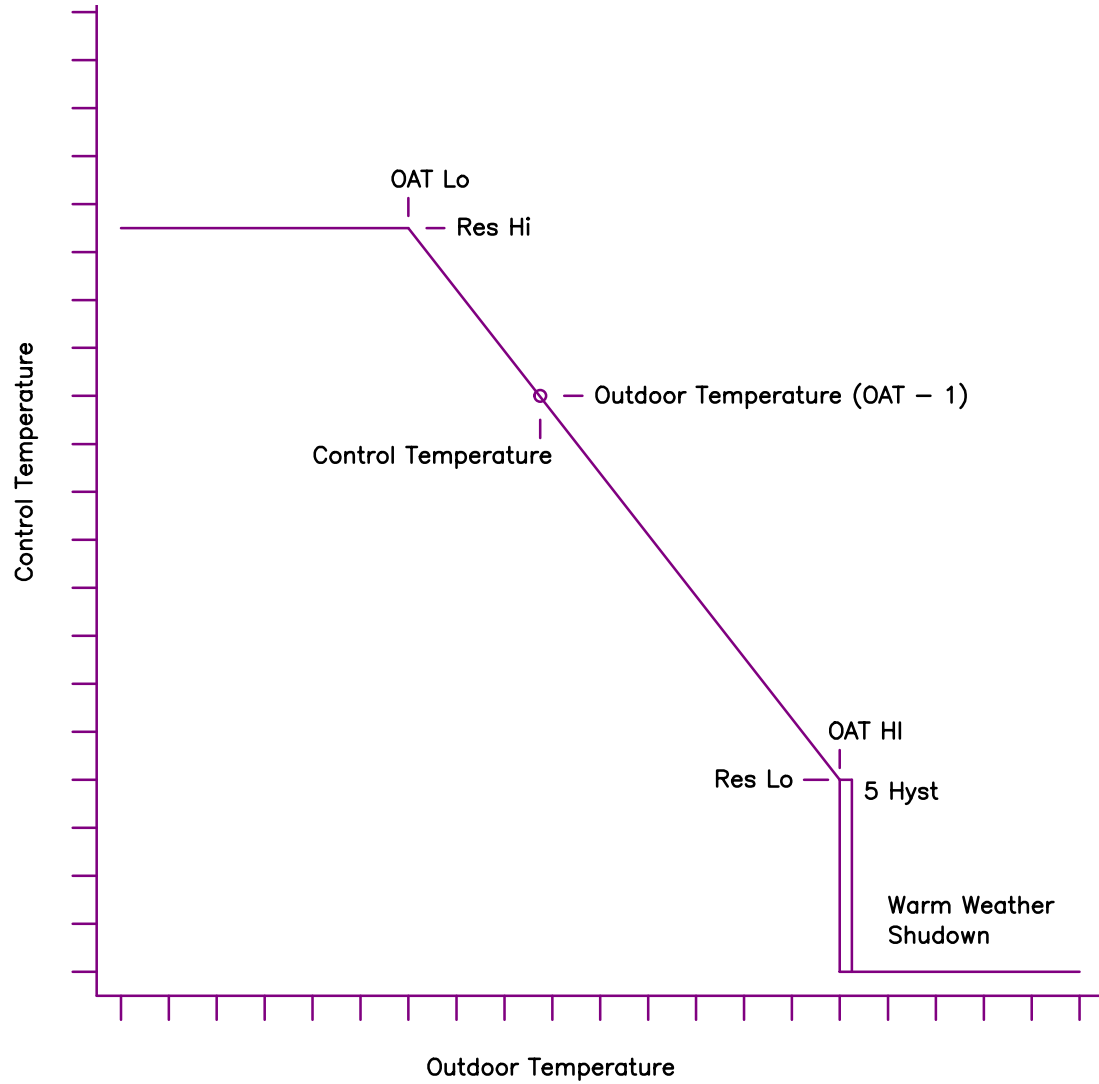

Then this Control Temperature and the current Reset Loop Temperature are used to calculate the Variable Speed Pump Output according to the graph below

## Variable Speed Output

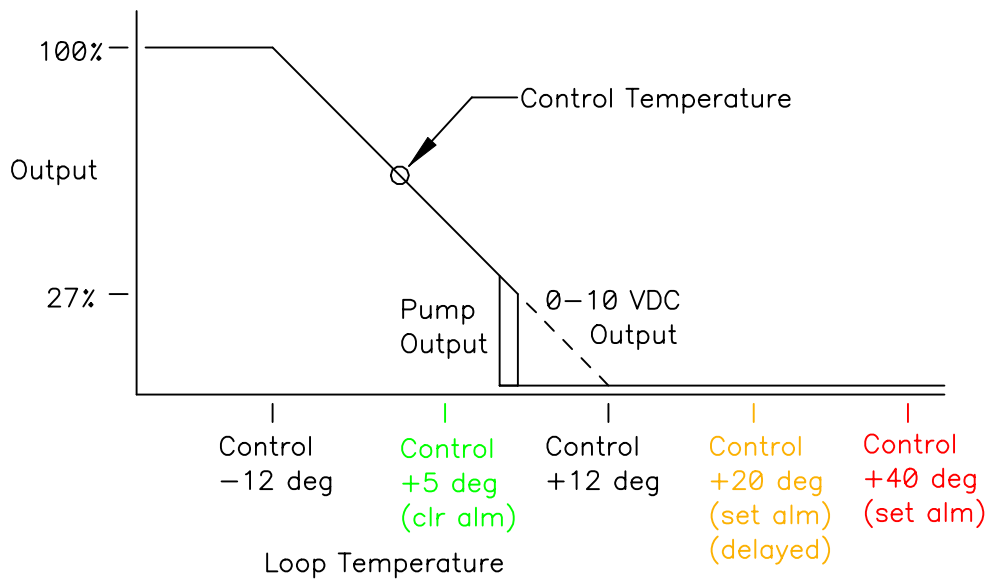

Once the output is determined it is send to the pump controller. This separate pump controller calculated the RMS voltages, monitors the line AC voltage, and times the triac. This controller will ensure the on/off duty cycle of the pump is limited to approximately 25 seconds. The controller also generates the full speed start pulse and limits the minimum speed to to variable pump to 27%, the 0-10 volt output is linear to 0% .

If the loop temperature is 40 degrees above the set point or 20 degrees above the set point for more than 5 seconds then the pump is turned off and an alarm generated until the loop temperature returns to 5 degrees above the set point.

### Boiler Protection Mode

If the return temperature falls below the BLR PRO set point for more than 5 seconds then the output to the injection as well as the auxiliary pump is decreased by 0.5% each second to a minimum of 27%. If the boiler temperature rises 15 Deg F above minimum boiler temperature, a heat demand can start to be satisfied. If there is a demand for aux heat ,it will be satisfied first. In this case a total time of 30 mins has to elapse from the time, the boiler temperature reaches minimum boiler temperature + 15DegF until a demand for the secondary loop can be satisfied. If there isa demand for heat but no demand for aux heat and the boiler temperature reaches minimum boiler temperature + 15 DegF, the injection pump can start immediately.

If no BLR sensor is used the default temperature is 205 degrees and boiler protection is disabled.

If a RM sensor is used it will call for heat as described above and will also modify the variable speed pump output. If the room temperature falls below the set point by more than 4 degrees the output will be increased 0.5% each 80 seconds to a maximum offset of 20% to compensate. Likewise, if the room temperature rises above the set point by more than 4 degrees the output will be decreased 0.5% each 80 seconds to a maximum offset of 20%. Once the room temperature returns to within 4 degrees of the set point the offset is turned off and the PSC-3 returns to its normal reset operating point. If no room sensor is used a default of 70 degrees is used which disables the room sensor adjustments and heat demand when the Room setting is left at its 70 degree default value.

### Pump Exercising

When pump exercising is selected the pumps will activate for 15 seconds if they are not used for more than 1 week. When an exercise cycle is active the display will read Exercise PIs Wait. Once the cycle is complete the Mighty Mix will return to normal operation.

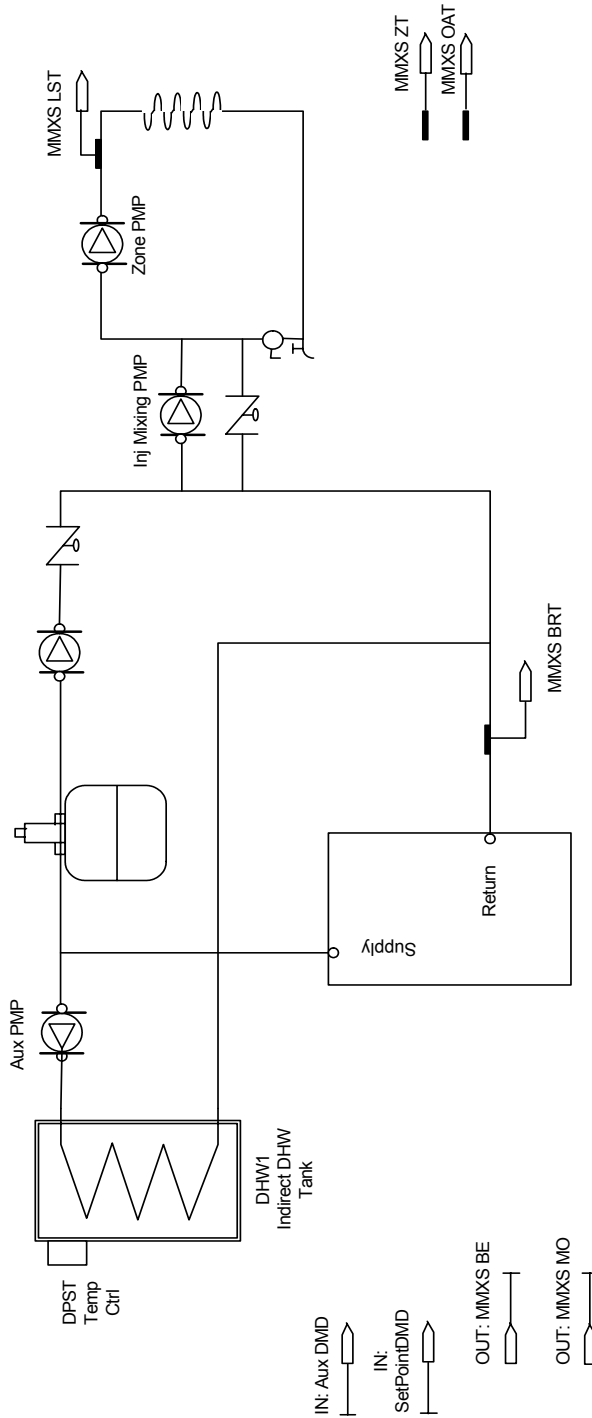



## Programming Mode

Once Program mode is entered the Program key will return directly to the Main Screen. All items set to this point will be saved. Each setting in Program Mode is made by pressing the Up or Down keys. After the displayed value is correct the Next key is pressed to enter the value and go to the next variable. The first setting allows the temperature to be displayed on degrees F or degrees C. Then each of the variables shown above in the Programming Display Window are set. Next the secondary pump is set to On or Auto. The last setting is setting the pumps exercise option on or off. After all settings are made they are saved and you are returned to the Main Screen.

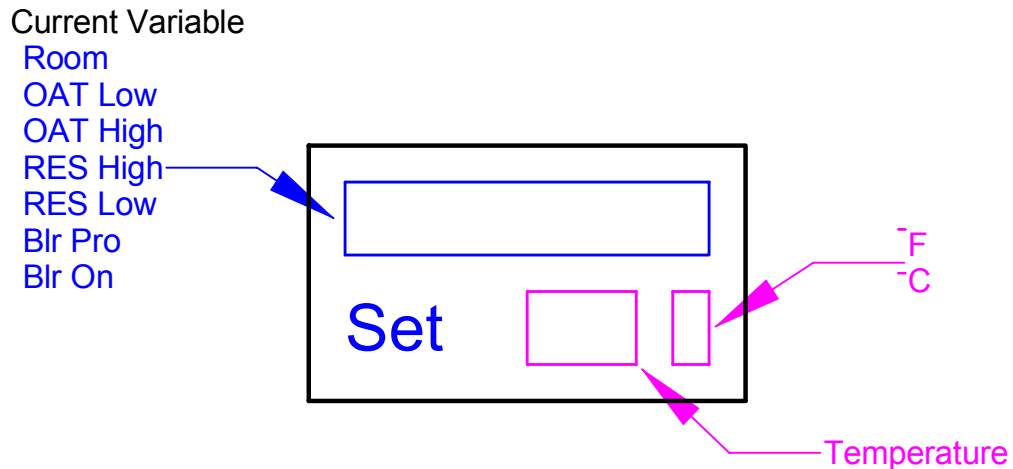

## Programming Display Window

### Pump Compatibility\*

The Mighty Mix is be compatible with the following pumps:

- Grundfos: Series UP
- Bell & Gossett: Series LR, NBF, NRF
- Taco: Series 00
- Armstrong: Series E

\*Compatibility means the the Mighty Mix can properly start the pump, and maintain the temperature at the desired setpoint without stalling, overheating or excessive cycling.

### Environmental Ratings

Operating Temperature: -25 to 50C (-13 to 122F)

Storage Temperature: -40 to 70C (-40 to 158F)

Humidity: 5 to 95% RH, noncondensing, drip-free environment

### Mounting

The enclosure is mounted to a wall or other surface via mounting slots provided in the rear of the enclosure.

