

AHU-1

The AHU-1 air handler controller is a stand-alone microprocessor based controller for single zone air handler units with an economizer. The application includes air handler units with modulated cooling, modulated heating and a modulated economizer.

Overview

Digital inputs are provided for fan status, freeze indication, smoke detector, and filter status. Analog inputs are provided for mixed air temperature, return air humidity and supply air temperature. A two wire serial interface is provided for the thermostat. Analog outputs are provided for the heating valve, cooling valve and economizer. The unit supply fan is controlled by a digital output in the form of triac. In addition, a digital output is provided to control a two-position economizer if required.

The controller is based on the LONWORKS® networking technology. The controller can be networked to a higher-level control system for monitoring and control applications.

Features

- Modulated cooling valve
- Modulated heating valve
- Modulated or two-position economizer control
- Local backup schedule
- Individual temperature setpoints for occupied/unoccupied heat and cool
- P+I Control of cooling, heating and economizer
- Economizer enabled based on enthalpy or dry bulb calculations
- LONWORKS interface to building automation systems and host products
- Mixed air low limit protection
- Filter status input
- Smoke detection input
- Thermostat with space temperature, setpoint adjust, fan override, occupancy override
- Fan control energized on call for heating or cooling
- Automatic heat/cool changeover
- Remote sensor capabilities
- Automatic configuration with the LCI
- Alarm/Event reporting

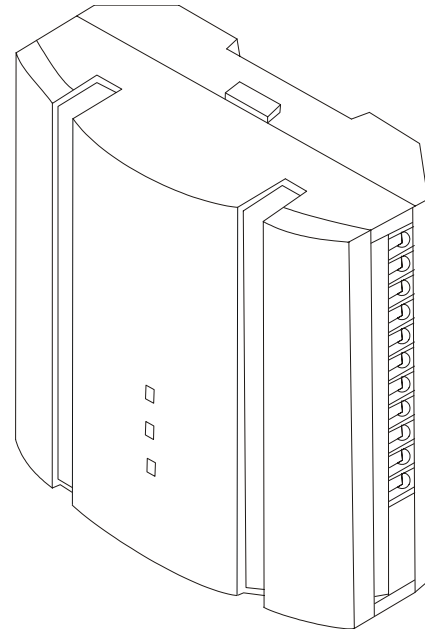

Innovex Technologies
511 Braddock Avenue
Turtle Creek, PA 15145
www.innovextechnologies.com

iWorX is a trademark of Innovex Technologies
LON, LONWORKS, & LONMARK are trademarks of Echelon Corporation

Purpose of This Guide

The *iWorX AHU-1 Application Manual* provides application information for the AHU-1 Controller.

The reader should understand basic HVAC concepts, intelligent environmental control automation, and basic LONWORKS networking and communications. This Application Manual is written for:

- Users who engineer control logic
- Users who set up hardware configuration
- Users who change hardware or control logic
- Technicians and field engineers

Copyright Notice

Copyright © 2005, Innovex Technologies

The confidential information contained in this document is provided solely for use by Innovex Technologies employees, licensees, and system owners, and is not to be released to, or reproduced for, anyone else. Neither is it to be used for reproduction of this control system or any of its components.

All specifications are nominal and may change as design improvements occur. Innovex Technologies shall not be liable for damages resulting from misapplication or misuse of its products.

Applicable Documentation

Part Number	Description	Audience	Purpose
iWorX-AHU-INS-100	iWorX AHU Series Installation Instructions	<ul style="list-style-type: none"> – Application Engineers – Installers – Service Personnel – Start-up Technicians 	Provides instructions for setting up and using the iWorX AHU-1 Controller.
iWorX-LCI1-USR-100	iWorX LCI User's Guide	<ul style="list-style-type: none"> – Application Engineers – Installers – Service Personnel – Start-up Technicians – End user 	Provides instructions for setting up and using the iWorX Local Control Interface.
iWorX-DTM-INS-100	iWorX DTM Series General Instructions	<ul style="list-style-type: none"> – Application Engineers – Installers – Service Personnel – Start-up Technicians 	Provides step-by-step installation and checkout procedures for iWorX Digital Thermostat Modules. Also contains instructions for sensor operation.
Additional Documentation	<i>LonWorks FTT-10A Free Topology Transceiver User's Guide</i> , published by Echelon Corporation. It provides specifications and user instructions for the FTT-10A Free Topology Transceiver.		

Application Description

The controller maintains the temperature of a space to the setpoint you define. Figure 1 and Figure 2 illustrate typical controller applications. The control is achieved by modulating the economizer dampers, heating valve, and cooling valve based on the current space requirements.

The controller controls the starting and stopping of the supply air fan. The fan will be energized when there is call for heating or cooling. During the occupied periods, the fan can be configured to run continuously. The fan can be overridden from the local thermostat. If overridden, the fan will run continuously.

The enthalpies of the outside and inside air are calculated periodically. A comparison will be performed to determine if “free cooling” is available. If “free cooling” is available, the economizer is enabled. Free cooling can also be enabled based on a dry-bulb comparison of the outdoor air temperature and indoor temperature. The system can use either a two-state or modulated economizer. If a two-position economizer is employed, it will be energized when there is a call for cooling, to take advantage of the energy savings. The two-position economizer output will be off when the economizer feature is disabled.

If a modulated economizer is employed, when “free cooling” is available, the modulated economizer position is calculated by a Proportional + Integral (P+I) control loop. The control is based on the mixed air temperature and setpoint. As the temperature increases above the mixed air setpoint, the economizer valve will be modulated open. The economizer will be modulated closed as the temperature decreases below the mixed air setpoint. The economizer will be modulated to its minimum position when the economizer is disabled. The economizer can optionally be disabled during unoccupied periods.

The cooling valve position is calculated by a Proportional + Integral control loop based on the space temperature and the cooling setpoint. As the temperature increases above the cooling setpoint, the cooling valve will be modulated open. The cooling valve will be modulated closed as the temperature decreases below the cooling setpoint. When unoccupied mode is entered, the cooling setpoint is setup.

Figure 1: Single Zone AHU-1 with Modulated Economizer

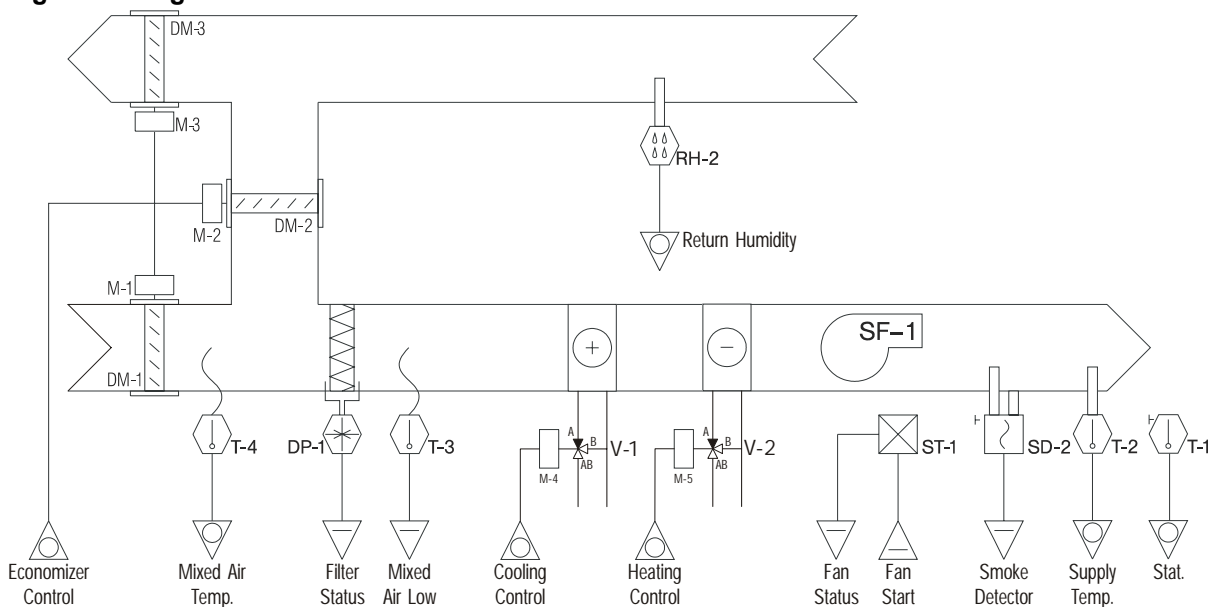

The heating valve position is calculated by a Proportional + Integral control loop based on the space temperature and the heating setpoint. As the temperature decreases below the heating setpoint, the heating valve will be modulated open. The heating valve will be modulated closed as the temperature increases above the heating setpoint. When unoccupied mode is entered, the heating setpoint is set back.

Each controller interfaces to a local thermostat. The thermostat includes a space temperature sensor, temperature setpoint adjustment, occupancy override, and a fan auto/on selection (depending on the model).

The controller operates in one of two states: occupied or unoccupied. The LCI determines the active operating mode. The controller maintains the comfort level to a user-defined setpoint during the occupied period. The controller uses setup and setback values during the unoccupied period to maintain the space temperature. An optional backup schedule is provided for cases when the LCI is not available.

A digital input is provided to monitor the status of the fan. If the fan is energized and no air flow is detected after 30 seconds, the controller closes the heating and cooling valves and turns off the supply fan. The controller will return to normal operation after a reset. An alarm will be reported to the LCI when this condition exists.

The controller monitors an input to determine the presence of smoke. When the input indicates smoke, the controller immediately turns off the fan and closes the heating and cooling valves. The controller will return to normal operation after a reset. An alarm is reported to the LCI when smoke is detected.

A digital input is provided on the controller to monitor the status of the air filter. An external pressure switch is wired to the input to determine when the filter becomes dirty. An alarm will be reported to the LCI when this condition exists.

Mixed air low limit protection is provided through a digital input. If a low limit condition exists, the controller opens the heating and cooling valves and turns off the supply air fan. An alarm will be reported to the LCI when this condition exists. The controller will return to normal operation after a reset.

The controller monitors the runtime of the fan. When the runtime exceeds a programmable limit, a maintenance alarm will be reported to the LCI.

When the space temperature exceeds a programmable limit, a high limit alarm will be reported to the LCI. When the space temperature drops below a programmable limit, a low limit alarm will be reported to the LCI. When the space temperature returns to the proper range, a return to normal alarm will be reported to the LCI.

Figure 2: Single Zone AHU-1 with Two-Position Economizer

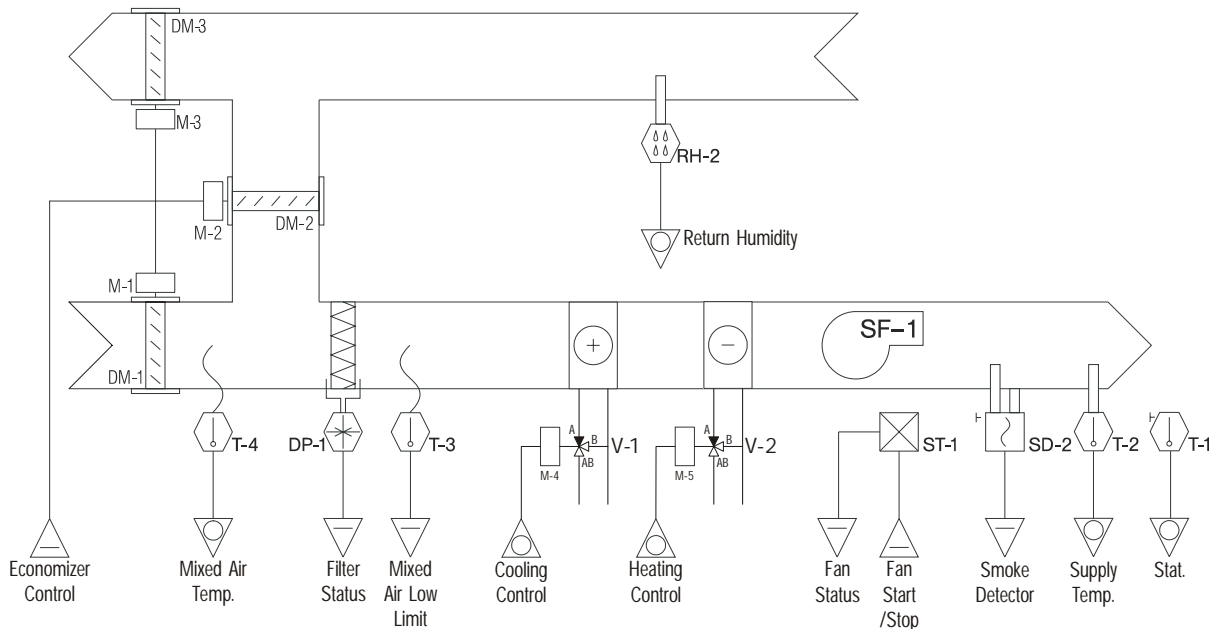

Sequence of Operation

This section describes the detailed sequence of operation for the controller control algorithms.

Figure 3: Cooling and Heating Valve Control.

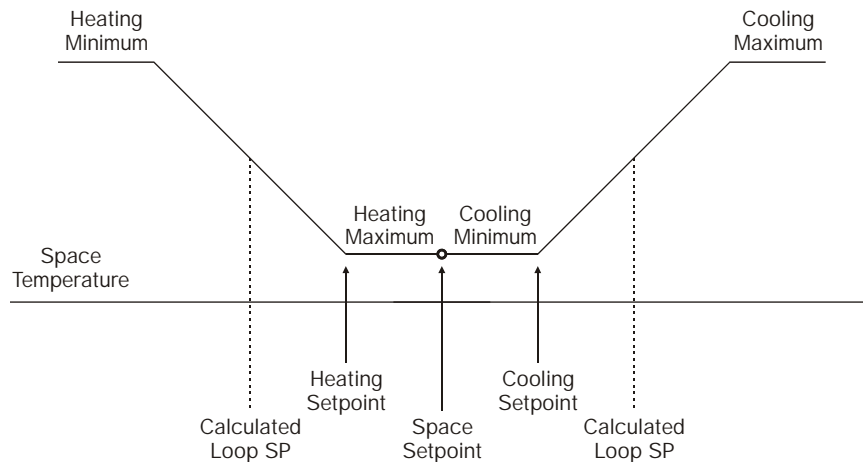

Setpoints

The heating and cooling setpoint for both occupied and unoccupied periods are programmable values. The space setpoint is a calculated value based on the programmed heating setpoint, cooling setpoint and current operating mode (i.e. occupied or unoccupied).

The space setpoint is derived by first calculating the zero energy band (zeb) for the current operating mode.

Occupied Mode

$$ZebOcc = OccupiedCoolSp \angle OccupiedHeatSp$$

Unoccupied Mode

$$ZebUnocc = UnoccupiedCoolSp \angle UnoccupiedHeatSp$$

The space setpoint is calculated from the zero energy band and the heating setpoint.

Occupied Mode

$$SpaceSP = OccupiedHeatsp + \frac{ZebOcc}{2}$$

Unoccupied Mode

$$SpaceSp = UnoccupiedHeatSp + \frac{ZebUnocc}{2}$$

Figure 4: Space Setpoint Calculation

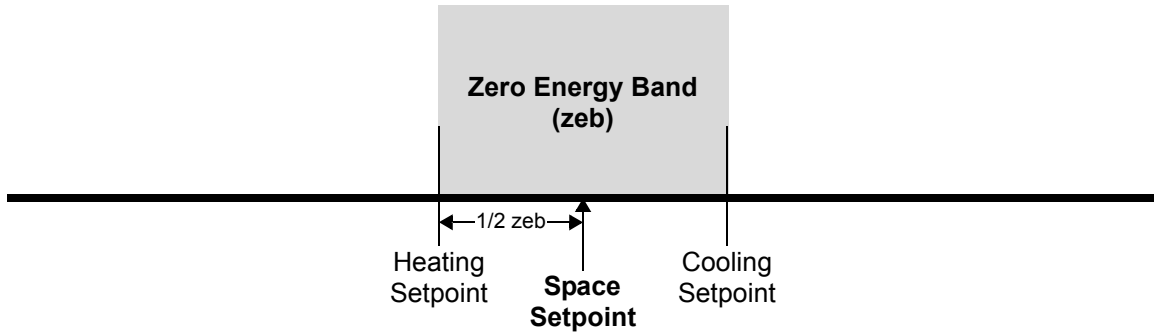

The effective setpoint is a calculated value based on the space setpoint and the thermostat setpoint offset value. The setpoint offset is used to increase or decrease the space setpoint from the local thermostat. The offset value is limited to plus or minus the programmed setpoint adjustment.

The setpoint offset also affects the *calculated heating* and *calculated cooling* setpoints by an equal amount. The setpoint offset only applies in the occupied mode of operation. It has no effect in the unoccupied mode. Note that the actual programmed heating and cooling setpoints are not changed. The offset is simply added to the programmed setpoints to derive the calculated values.

Occupied Mode

$$CalcCoolingSp = OccupiedCoolingSp \pm SpOffset$$

$$CalcHeatingSp = OccupiedHeatingSp \pm SpOffset$$

$$EffectiveSp = SpaceSp \pm SpOffset$$

Unoccupied Mode

$$CalcCoolingSp = UnoccupiedCoolingSp$$

$$CalcHeatingSp = UnoccupiedHeatingSp$$

$$EffectiveSp = SpaceSp$$

Figure 5: Setpoint Adjustment

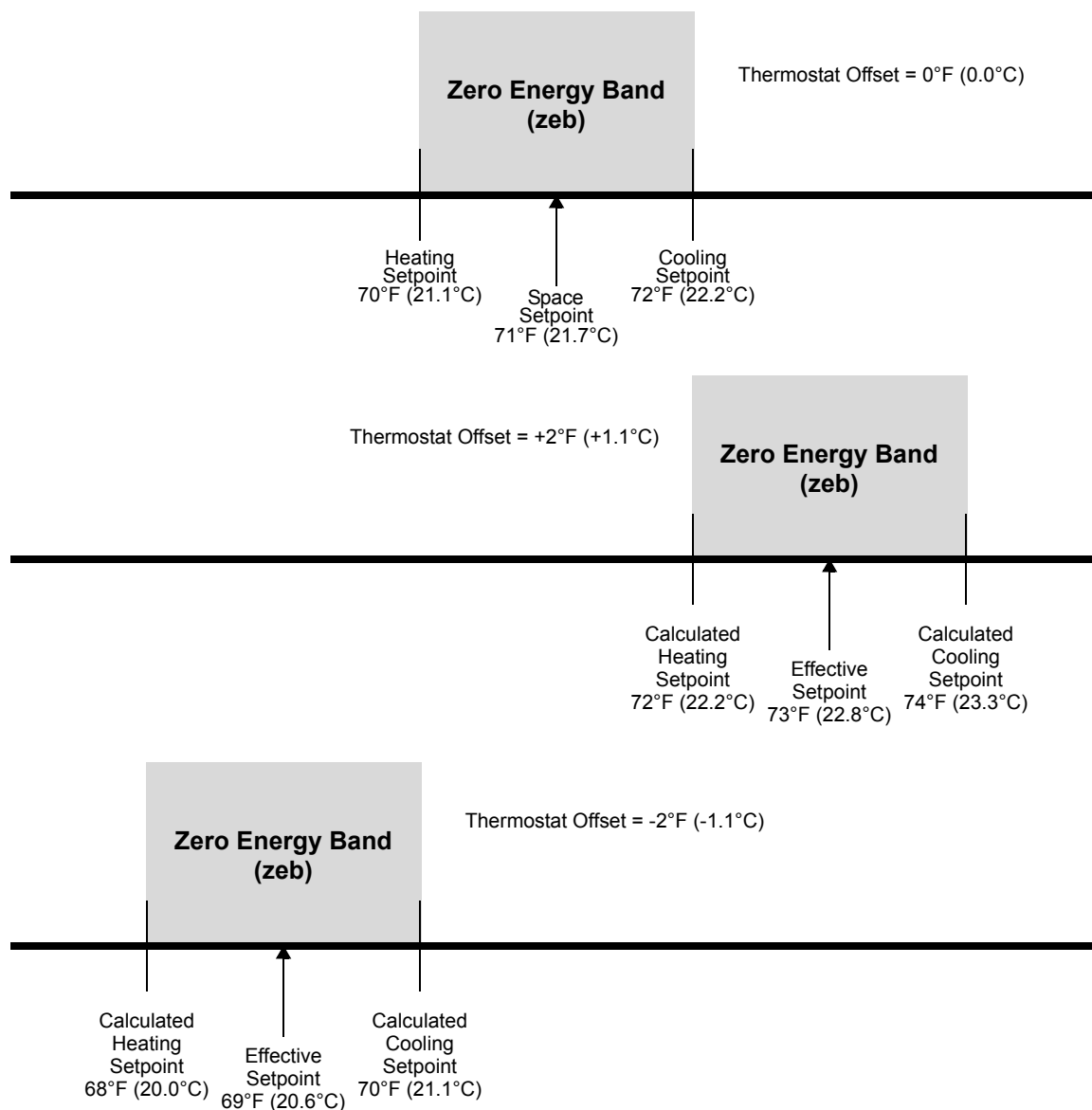

Heating Control

The *calculated heating loop setpoint* is derived from the heating setpoint and the loop proportional gain.

$$\text{CalcHeatingLoopSp} = \text{CalcHeatingSp} \angle \frac{1}{2(K_p)}$$

The heating valve is modulated by a Proportional + Integral (P+I) control loop based on the heating loop setpoint and the space temperature. The P+I control loop will modulate the valve to maintain a constant space temperature. As the temperature decreases below the heating loop setpoint, the heating valve will be modulated open. The heating valve will be modulated closed as the temperature increases above the heating loop setpoint. When unoccupied mode is entered, the heating loop setpoint is set back through a separate unoccupied heating setpoint.

To prevent the integral component from becoming too large, there is anti-wind up reset protection. This protection clamps the integral value when all of the components add up to more than 100% or less than 0%. The following equations are used for P+I control:

$$K_p = \text{Proportional Gain}$$

$$K_i = \text{Integral Gain}$$

$$\text{Error} = \text{HeatingLoopSp} \angle \text{SpaceTemp}$$

$$I = I + (K_i \times \text{Error})$$

$$\text{HeatPosition} = (K_p \times \text{Error} + I) + 50.00\%$$

Cooling Sequence

The *calculated cooling loop setpoint* is derived from the calculated cooling setpoint and the loop proportional gain.

$$\text{CalcCoolingLoopSp} = \text{CalcCoolingSp} + \frac{1}{2(K_p)}$$

The cooling valve is modulated by Proportional + Integral (P+I) control loop based on the cooling loop setpoint and space temperature. The P+I control loop will modulate the valve to maintain a constant space temperature. As the temperature increases above the cooling loop setpoint, the cooling valve will be modulated open. The cooling valve will be modulated closed as the temperature decreases below the cooling loop setpoint. When unoccupied mode is entered, the cooling setpoint is setup through a separate unoccupied cooling setpoint.

To prevent the integral component from becoming too large, there is anti-wind up reset protection. This protection clamps the integral value when all of the components add up to more than 100% or less than 0%. The following equations are used for P+I control:

$$K_p = \text{Proportional Gain}$$

$$K_i = \text{Integral Gain}$$

$$\text{Error} = \text{SpaceTemp} \angle \text{CoolingLoopSp}$$

$$I = I + (K_i \times \text{Error})$$

$$\text{CoolPosition} = (K_p \times (\text{Error} + I)) + 50.00\%$$

Economizer Operation

The controller provides support for either two-position or modulated economizer types. You can specify which type of economizer you are using through a configuration parameter. Both economizer types are enabled based on the availability of “free cooling” from the outdoor air. Free cooling can be determined by dry bulb or enthalpy comparisons.

Dry Bulb Comparisons

Free cooling can be determined based on a comparison of outdoor air temperature and indoor air temperature. When the outdoor air temperature is a programmable amount below the indoor air temperature, free cooling is enabled. When the outdoor air temperature rises above the indoor temperature, free cooling is disabled.

Enthalpy Calculations

An enthalpy calculation is performed periodically to determine if “free cooling” is available from the outside air. The outside enthalpy is calculated based on the outside air temperature and humidity. The outside temperature and humidity are measured by an external device (such as an ASM-1) on the network and sent to the controller. The same calculation is performed on the inside air based on the space temperature and return air humidity. The inside enthalpy minus the outside enthalpy must be greater than the Free Cooling Setpoint in order for the economizer to be used for free cooling.

Optionally, an external device can measure the indoor air humidity globally. In this case, a return air humidity sensor would not be required at each AHU-1.

Two-position Economizer Control

If present, the two-position economizer is enabled when there is “free cooling” available as determined by the enthalpy calculations. When the economizer is enabled, the economizer digital output will be energized. When the economizer is disabled, the economizer output will be de-energized. A configuration parameter is available to optionally disable the economizer during unoccupied periods.

Modulated Economizer Control

If present, the modulated economizer is enabled when there is “free cooling” available as determined by the enthalpy calculations.

Figure 6: Economizer Control

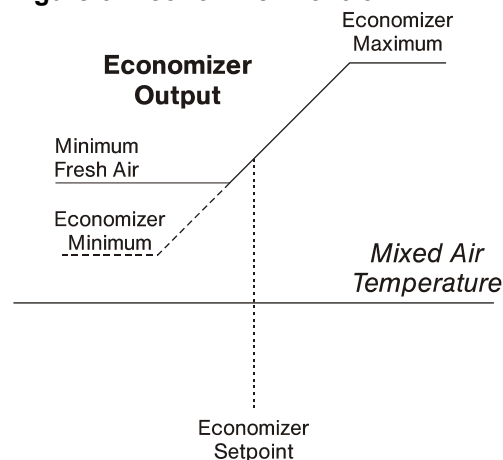

When the economizer is enabled, a Proportional + Integral (P+I) control loop modulates the economizer output position to maintain a constant mixed air temperature

The Proportional + Integral (P+I) control loop is based on the economizer setpoint and mixed air temperature. As the temperature increases above the economizer setpoint, the economizer will be modulated open. The economizer will be modulated closed as the temperature decreases below the economizer setpoint.

To prevent the integral component from becoming too large, there is anti-wind up reset protection. This protection clamps the integral value when all of the components add up to more than 100% or less than 0%. The following equations are used for P+I control:

$$K_p = \text{ProportionalGain}$$

$$K_i = \text{IntegralGain}$$

$$\text{Error} = \text{MixedAirTemp} \angle \text{EconSp}$$

$$I = I + (K_i \times \text{Error})$$

$$\text{EconPosition} = (K_p \times (\text{Error} + I)) + 50.00\%$$

When the economizer is disabled, it will modulate to the minimum position. A configuration parameter is available to optionally disable the economizer during unoccupied periods.

Fan Operation

During occupied periods, you can set the fan to always run or to cycle off when the space temperature is within the zero energy band. The zero energy band is defined as the temperature range between the cooling and heating setpoints. The fan is interlocked with the cooling and heating control loops. If there is a call for heating or cooling the fan will immediately energize. During the unoccupied period, the fan will always cycle off when the space temperature is within the zero energy band.

You can override the fan from the local thermostat (depending on the model). When the fan selection is set to *Auto*, the fan operates as described above. If the fan selection is set to *On*, the fan will be constantly on.

Fan Proof

When there is a call for heating or cooling, the fan output is energized. A fan status input is provided for monitoring the operation of the fan. When the fan is initially turned on, there is a 30 second delay before the fan status is checked. If at any time after the delay, the fan status indicates the fan is not running, a fan failure condition is generated. The heating, cooling and economizer are interlocked with the fan. When a fan failure condition exists, the heating and cooling valves will close and the fan will immediately turn off. The controller must be reset to clear this condition.



Note: If you are not providing a fan status switch, the input must be jumpered to the adjacent common. After a fan failure, the controller's status LED will go solid red. To return the controller to normal operation after the failure condition is resolved, you must reset the controller by removing and reapplying power or by using the controller reset feature on the LCI. (See the *LCI User's Guide* for details.)

Smoke Detection

A smoke detector input is provided. If the smoke detector indicates smoke is present, the heating and cooling valves will close and the fan will turn off. Reset the controller to clear this condition.

Mixed Air Low Limit Detection

An input is provided for a mixed air low limit detection device. If a low limit condition is detected, the heating and cooling valves will close and the fan will turn off. Reset the controller to clear this condition. (After the AHU-1 switches from unoccupied mode to occupied mode, there is a ten minute delay before it will report Mixed Air Low Limit alarms.)

Filter Status

The filter status input is monitored to determine if the filter is operating properly. The input is used to indicate that maintenance is required on the filter. The controller application is not shut down due to a filter alarm.

Thermostat

The space temperature value, setpoint adjustment, fan auto/on status (depending on the thermostat model), and occupancy override request are monitored by the thermostat and sent to the controller.

The controller will automatically detect a failure of the thermostat. When the thermostat fails, the heating and cooling valves will close, the fan will and fan will turn off, and control will be disabled.



Note: The thermostat must be connected. The status LED on the controller will turn solid red if the thermostat is not connected. Once the thermostat is connected, the status LED will turn green indicating normal operation.

Local Backup Schedule

The LCI normally determines the operating mode. You can define a local backup schedule for situations when the LCI is not available. When the controller detects that the LCI is not available (after 10 minutes without communication), it resorts to the local backup schedule that you have configured. If the local backup schedule is disabled, the controller defaults to occupied mode.

You configure the *occupied* and *unoccupied* times that are used in determining the current operating mode of the controller when it is running the backup schedule. By default, both the unoccupied and occupied time will be set to zero, which disables the local backup schedule. This causes the controller to default to the occupied mode of operation if it cannot communicate with the LCI.

Runtime Accumulation

The total runtime is accumulated for the fan output. The runtime can be used to indicate that maintenance is required on the fan. The runtime can be reset by an operator or maintenance person once servicing has been performed.

Alarms and Events

The controller will detect certain alarm conditions and send them to the LCI. Before this can occur, you must use the LCI to configure the controller.

Digital Input Alarm

The controller monitors the status of the digital inputs and generates alarms for the following events:

- Fan failure (Fan Failed Alarm)
- Smoke detect (Smoke Detected Alarm)
- Mixed air low limit condition (Low Limit Alarm)
- Dirty filter (Dirty Filter Alarm)

Thermostat Failure

The controller automatically detects the presence of the local thermostat and monitors its status. If the thermostat fails to communicate with the controller, a Thermostat Failed Alarm will be generated and the controller's status LED will turn red.

Maintenance Alarm

The controller provides a single programmable run limit for generating a runtime Maintenance Alarm. When the fan runtime exceeds this limit, a maintenance alarm is sent to the LCI.

Space Temperature Alarms

The controller generates high and low limit alarms for the space temperature. You can configure a programmable space temperature alarm limit offset. The temperature limits are calculated based on the control setpoints, alarm limit offset, and control band.

$$\text{HighLimit} = \text{CalcCoolingSp} + \text{AlarmLimitOffset} + \text{CoolBand}$$

$$\text{LowLimit} = \text{CalcHeatingSp} \angle \text{AlarmLimitOffset} \angle \text{HeatBand}$$

When the measured space temperature exceeds the high limit, a high limit alarm (Space Temperature High Limit Alarm) is generated. When the space temperature drops below the low limit, a low limit alarm is generated (Space Temperature Low Limit Alarm). A return to normal alarm is generated when the space temperature is between the high and low limit (Space Temperature Return to Normal).

When the controller switches between the unoccupied and occupied modes of operation, no space temperature alarms are reported for 30 minutes following the switch. This helps eliminate nuisance alarms.

Controller Identification

You need to press the controller's service pin to allow the LCI to identify it. The controller's status light will be flashing green until it is configured, and will be solid green after it is configured. The controller must be configured by the LCI to allow you to use the LCI to set the controller's schedules, change its setpoints, etc. You need to press the service pin after the controller is installed and the LCI is active on the network.

Troubleshooting

Diagnostic LEDs

The controller has 3 LED indicators. These indicators can aid in troubleshooting equipment operation problems. The following table lists the function of each LED in the order it appears from top to bottom on the unit.

Figure 7: Controller LED Indicators

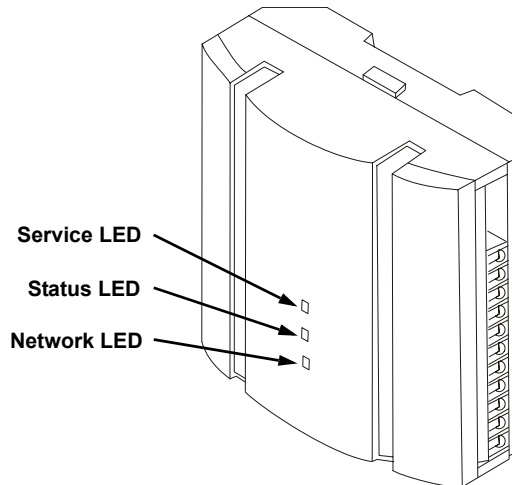

Table 1: AHU-1 Controller LEDs

LED	Indication
Service	Illuminated when the service pin is pushed
Status	Solid green when running and configured by an LCI Flashing green when running and NOT configured by an LCI Solid red when a fault condition exists
Network	Yellow while the controller is transmitting data onto the FTT-10A network Green when there is network activity Off when there is no network activity

Troubleshooting Tips

Controller is not running and Status LED is not illuminated.

No power to controller. Verify the voltage on the controller's power connector (24 VAC).

Fan cycles on for 30 seconds but then turns off.

The controller requires the fan proof input to be shorted, normally closed, for proper operation. Ensure that your air flow sensor is working and properly wired. If you are not using an air flow sensor you must place a jumper between the fan proof input and adjacent common terminal.

The fan will not cycle on after the input has been jumpered or the air flow sensor connected.

If the fan was previously in a fan proof fault condition, the controller must be reset before proper operation can be restored.

How do I reset the controller?

The controller can be reset by the LCI, or you can cycle power to the controller. Refer to the LCI documentation for more information on resetting the controller using the LCI.

The fan will not cycle on.

There are several reasons the fan may not cycle on, and all should be checked.

1. Remember, all digital inputs on the controller (with the exception of the fan status input) are normally open and should be wired accordingly.
2. Is the controller in an occupied mode?
3. Has the controller been overridden by the LCI?
4. Check to see if the smoke detector or mixed air low limit sensors are tripped. If so, correct the problem and reset the controller.
5. Verify that the thermostat is connected.

The fan pilot relay will not come on even though the LCI indicates it is on.

Ensure that the controller and fan pilot have been powered with 24 VAC and the output has been correctly wired to the coil of the pilot relay. Also ensure that the pilot relay has a 24 VAC coil.

The economizer damper fails to open.

1. The economizer damper will not open if the difference between the outdoor air temperature and the indoor air temperature is less than the differential setpoint, or if the inside air enthalpy is less than the outside air enthalpy.
2. Was the LCI used to select an economizer type other than 'None'?

The 10K thermistor reading is at its maximum or minimum.

The input is either shorted or open.

Network Variables and Configuration Variables

This section describes all of the Network and Configuration Variables used in the controller.

Table 2: AHU-1 Inputs

LCI Variable Name	Range	Default Value	Description
Space Temperature	-22 °F to 122 °F (-30 °C to 50 °C), or Auto	Auto	Network override of the actual space temperature provided by the local thermostat
Temp Setpoint	50 °F to 95 °F (10 °C to 35 °C), or Auto	Auto	Network override for effective setpoint (when not in Auto, value overrides thermostat)
Occupancy Cmd	Occ, Unocc, Bypass, Auto	Auto	Network override for occupancy command
Reset Runtimes	Off, On	Off	Resets the runtime hours for fan (can be set through LCI interface)
System Time	00:00 to 23:59	00:00	System clock value (not used by LCI)
Outside Temp	-22 °F to 122 °F (-30 °C to 50 °C), or Not Avail	Not Avail	Reading from external outside air temperature sensor
Outside Humidity	0.00% to 100.00%, or Not Avail	Not Avail	Reading from external outside air humidity sensor
Indoor Air Humidity	0% to 100%, or Not Avail	Not Avail	Reading from external indoor air humidity sensor

The following output variables are read only and cannot be changed.

Table 3: AHU-1 Outputs

LCI Variable Name	Range	Description
Space Temperature	-22 °F to 122 °F (-30 °C to 50 °C)	Measured space temperature
Mode	Auto, Heat, Cool, Off, Fan	Operating mode
Heat Output	0 to 100%	Capacity of heating used
Cool Output	0 to 100%	Capacity of cooling used
Economizer Output	0 to 100%	Capacity of economizer used
Fan Output	0 to 100%	Off=0, ON=100%
In Alarm?	No, Yes	Alarm indication
Effective Setpt	50 °F to 95 °F (10 °C to 35 °C)	Effective temperature setpoint
Occ. Ext. Time Rem.	0 to 1000 minutes	Occupancy override time remaining
Smoke Detector	Normal, Smoke	Current state of the smoke detector input
Fan Status	Off, On	Current state of the fan proof input
Low Limit	Normal, Low Limit	Current state of the mixed air low limit input
Filter Status	Normal, Dirty	Current state of the filter status input
Occupancy Mode	Occ, Unocc, Bypass	Current occupancy mode
Fan Runtime	0 to 65,535 hours	Runtime hours for the fan
Supply Air Temp	-22 °F to 122 °F (-30 °C to 50 °C)	Current value of the supply air temperature
Mixed Air Temp	-22 °F to 122 °F (-30 °C to 50 °C)	Current value of the mixed air temperature
Return Air Humidity	0.00 to 100.00%	Current value of the return air humidity
In Enthalpy	0 to 60.0 BTU/LB	Current value of the inside enthalpy calculation
Out Enthalpy	0 to 60.0 BTU/LB	Current value of the outside enthalpy calculation

Table 4: AHU-1 Setpoints

LCI Variable Name	Range	Default Value	Description
Occupied Cool	50 °F to 95 °F (10 °C to 35 °C)	72°F (22.2 °C)	Occupied cooling setpoint
Unoccupied Cool	50 °F to 95 °F (10 °C to 35 °C)	82°F (27.8 °C)	Unoccupied cooling setpoint
Occupied Heat	50 °F to 95 °F (10 °C to 35 °C)	70°F (21.1 °C)	Occupied heating setpoint
Unoccupied Heat	50 °F to 95 °F (10 °C to 35 °C)	60°F (15.6 °C)	Unoccupied heating setpoint
Space Temp Limit	0 °F to 15 °F (0 °C to 8.3 °C)	5 °F (2.8 °C)	Space temperature limit offset for alarming purposes
Heat Prop. Gain	0.0 to 100.00% per °F	50%	Proportional gain of the heat valve P+I control loop
Heat Integ. Gain	0.00 to 100.00%	0.10%	Integral gain of the heat valve P+I control loop
Heat Min Output	0.0 to 10.0 Volts	0.0 Volts	Minimum output value of the modulated heating valve output
Heat Max Output	0.0 to 10.0 Volts	10.0 Volts	Maximum output value of the modulated heating valve output
Cool Prop. Gain	0.0 to 100.00% per °F	50%	Proportional gain of the cool valve P+I control loop
Cool Integ. Gain	0.00 to 100.00%	0.10%	Integral gain of the cool valve P+I control loop
Cool Min Output	0.0 to 10.0 Volts	0.0 Volts	Minimum output value of the modulated cooling valve output
Cool Max Output	0.0 to 10.0 Volts	10.0 Volts	Maximum output value of the modulated cooling valve output
Fan Type	Auto, On	Auto	Type of fan operation
Setpoint Adjust	0 °F to 10 °F (0 °C to 5.6 °C)	5 °F (2.8 °C)	Allowed range of the setpoint adjustment
Occ. Extend Time	0 to 1000 minutes	60 minutes	Allowable occupancy extension time
Economizer Type	Disabled, 2 state Unocc ON, 2 state Unocc OFF, Mod. Unocc ON, Mod. Unocc OFF	Disabled	Type and state of economizer
Econ. Setpt.	40 °F to 70 °F (4.4 °C to 21.1 °C)	55.0 °F (12.8 °C)	Setpoint of the Proportional + Integral (P+I) loop controlling the modulated economizer
Econ. Prop. Gain	0.00 to 100.00% per °F	25.00%	Proportional gain of the economizer P+I control loop
Econ. Integ. Gain	0.00 to 100.00%	0.10%	Integral gain of the economizer P+I control loop
Econ. Min Position	0.00 to 100.00%	0.00%.	Minimum fresh air position for the modulated economizer
Free Cooling Type	OAH & Local indoor enthalpy, OAH & Global indoor enthalpy, Dry bulb comparison	Outdoor & Local	Type of free cooling comparison to perform
Free Cooling Enthalpy Setpoint	0 to 60 BTU/lb. (0 to 139.6 Kjoules/kg)	50 BTU/lb. (11.6 Kjoules/kg)	Differential setpoint to enable economizer.
Outdoor Temperature Offset	0 °F to 20 °F (0 °C to 11.1 °C)	5 °F (2.8 °C)	Difference between outdoor temp. and indoor temp. necessary to enable free cooling.
Econ. Min Output	0.0 to 10.0 Volts	0.0 Volts	Minimum output value of the modulated economizer output

Table 4: AHU-1 Setpoints

LCI Variable Name	Range	Default Value	Description
Econ. Max Output	0.0 to 10.0 Volts	10.0 Volts	Maximum output value of the modulated economizer output
Fan Runtime Limit	0 to 65,535 hours	1000 hours	Runtime limit for fan
Occupied Time	00:00 to 23:59	00:00	Occupied time for local backup schedule (if both Occupied Time and Unoccupied Time are zero, the local backup schedule is disabled)
Unoccupied Time	00:00 to 23:59	00:00	Unoccupied time for local backup schedule

Wiring Information

Terminal Identification

Figure 8: AHU-1 Terminal Connections

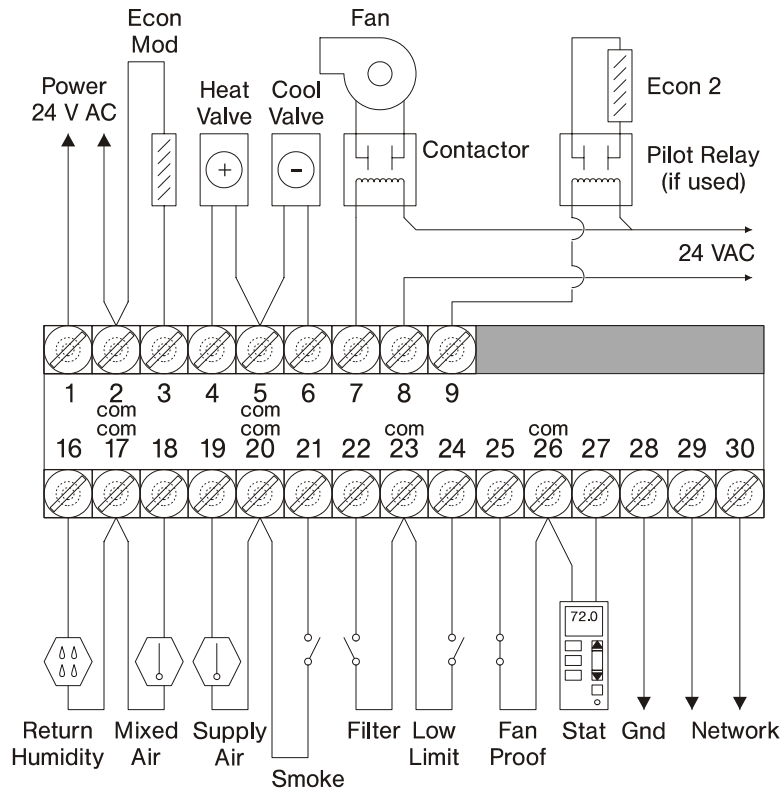

Input Devices

Return Humidity (RAH) (Optional)

To connect the Return Humidity sensor to the unit, connect the positive wire from the sensor to RAH (T16) and the other wire to the adjacent common (T17). The sensor must be of the 0-10 Volt type.

If global indoor air humidity readings will be provided over the network, it is not necessary to attach a return air humidity sensor directly to the AHU-1.

Mixed Air (MAT)

To connect the Mixed Air thermistor to the unit, attach one wire from the thermistor to MAT (T18) and the other wire to the adjacent common (T17). The thermistor used must be 10K Precon Type III.

Supply Air (SAT)

To connect the Supply Air thermistor to the unit, attach one wire from the thermistor to SAT (T19) and the other wire to the adjacent common (T20). The thermistor used must be 10K Precon Type III.

Smoke Detector (SMK)

To connect the smoke detector switch to the digital input, attach one wire of the contact to SMK (T21) and the other wire to the adjacent common (T20). This must be a dry contact normally open switch. This input is for indication only. A separate smoke detector should be wired into a fire alarm system if the generation of a fire alarm is required.

Filter (FIL)

To connect the filter switch to the digital input, attach one wire of the contact to FIL (T22) and the other wire to the adjacent common (T23). This must be a dry contact normally open switch.

Mixed Air Low Limit (MLL)

To connect the mixed air low limit switch to the digital input, attach one wire of the contact to MLL (T24) and the other wire to the adjacent common (T23). This must be a dry contact normally open switch.

Fan Proof (FNP)

To connect the fan proof switch to the digital input, attach one wire of the contact to FNP (T25) and the other wire to the adjacent common (T26). This must be a dry contact normally closed switch. If you are not providing a fan proof input, T25 and T26 must be shorted (jumpered) together.

STAT (S-LK)

Connect one wire of an iWorX Stat device to the S-LK (T27) terminal. Connect the other wire to the adjacent common (T26).

Output Devices**Modulated Economizer (ECA)**

The modulated economizer output can be set to 0-10 V maximum through the control logic. The positive signal input to the economizer should be connected to ECA (T3) and the other economizer wire should be connected to the adjacent common (T2).

Heating Valve (HV)

The heating valve output can be set to 0-10 V maximum through the control logic. The positive signal input to the heating valve should be connected to the output terminal HV (T4) and the other wire from the heating valve should be connected to the adjacent common terminal (T5).

Cooling Valve (CV)

The cooling valve output can be set to 0-10 V maximum through the control logic. The positive signal input to the cooling valve should be connected to the output terminal CV (T6) and the other wire from the cooling valve should be connected to the adjacent common terminal (T5).

Two Position Economizer (ECD)

The two position economizer output must be connected to a 24 VAC pilot relay or contactor. See Figure 8 on page 17 for details.

Fan (FAN)

The fan output must be connected to a 24 VAC pilot relay or contactor. See Figure 8 on page 17 for details.

Other Connections

Network (LON)

Network wiring must be twisted pair. One network wire must be connected to one LON (T29) terminal and the other network wire must be connected to the other LON (T30) terminal. Polarity is not an issue since an FTT-10A network is used for communications.

Power (PWR)

Connect one output wire from a 24 VAC power supply to PWR (T1) and the other output wire from the power supply to the adjacent common terminal (T2).

Specifications

Electrical

Inputs

- Cabling: twisted shielded pair, 18 AWG recommended—500 feet max. (152 meters)
- Resolution: 10 bit

Return Humidity

- 0-10 Volt

Mixed Air and Supply Air

- Precon Type III 10K thermistor

Fan Proof

- Dry Contact
- Normally Closed

Filter, Mixed Air Low Limit, and Smoke

- Dry Contact
- Normally Open

Thermostat Network

- 12 Volt nominal, internally limited to 0.04 A

Outputs

Economizer DO and Fan

- 24 Volts AC Triac
- 1 A rms

Economizer AO, Cooling Valve, and Heating Valve

- 0-10 Volt
- 2K Ohm minimum load
- 8 bit resolution

FTT-10A Network

- Speed: 78 KBPS
- Cabling: Maximum node-to-node distance: 1312 feet (400 meters)
- Maximum total distance: 1640 feet (500 meters)

Table 5: Network Wire Specifications

Cable Type	Pairs	Details	Connect Air Catalog No.
Level 4 22AWG (0.65mm)	1	Unshielded, Plenum, U.L. Type CMP	W221P-2001
Level 4 22AWG (0.65mm)	1	Unshielded, Non-Plenum, U.L. Type CM	W221P-1002

For detailed specifications, refer to the FTT-10A Free-Topology Transceiver User's Guide published by Echelon Corporation. For information on ordering Connect Air items, contact Connect Air International; 4240 B Street; Auburn, WA 98001 <www.connect-air.com>.

Power

Power Requirements

- 24VAC (requires an external supply)

Power Consumption

- With no external loads: 15 VA

Mechanical

Housing

- Dimensions: 4 3/8" high, 4 5/16" wide, 2" deep (111 mm high, 110 mm wide, 51 mm deep)
- ABS Polycarbonate

Electronics

- Processor: 3150 Neuron 10 MHz
- Flash: 48 Kilobytes
- SRAM: 8 Kilobytes
- Termination: 0.197" (5.0 mm) Pluggable Terminal Blocks, 14-22 AWG

Environmental

- Temperature: 32 °F to 122 °F (0 °C to 50 °C)
- Humidity: 0 to 95%, non-condensing

Agency Listings

- UL916

Agency Compliances

- FCC Part 15 Class A
- CE