

Features(cont.)

- Automatic heat/cool changeover
- Automatic configuration with the LCI
- Alarm/Event reporting

Purpose of This Guide

The *iWorX DXU-3/4 Application Manual* provides application information for the DXU-3/4 Controller.

The reader should understand basic HVAC concepts, intelligent environmental control automation, and basic LonWORKS networking and communications. This Application Manual is written for:

- Users who engineer control logic
- Users who set up hardware configuration
- Users who change hardware or control logic
- Technicians and field engineers

Copyright Notice

This document copyright © 2006, Innovex Technologies. All other intellectual property rights and copyrights related to or arising from these products belong to a third party.

The confidential information contained in this document is provided solely for use by Innovex Technologies employees, licensees, and system owners, and is not to be released to, or reproduced for, anyone else. Neither is it to be used for reproduction of this control system or any of its components.

All specifications are nominal and may change as design improvements occur. Innovex Technologies shall not be liable for damages resulting from misapplication or misuse of its products.

Applicable Documentation

Part Number	Description	Audience	Purpose
iWorX-DXU-INS-100	iWorX DXU Series Installation Instructions	<ul style="list-style-type: none"> – Application Engineers – Installers – Service Personnel – Start-up Technicians 	Provides instructions for setting up and using the iWorX DXU-3 controller.
iWorX-LCI2-USR-100	iWorX LCI User's Guide	<ul style="list-style-type: none"> – Application Engineers – Installers – Service Personnel – Start-up Technicians – End user 	Provides instructions for setting up and using the iWorX Local Control Interface.
iWorX-DTM-INS-100	iWorX DTM Series General Instructions	<ul style="list-style-type: none"> – Application Engineers – Installers – Service Personnel – Start-up Technicians 	Provides step-by-step installation and checkout procedures for iWorX Digital Thermostat Modules. Also contains instructions for sensor operation.
Additional Documentation	<i>LonWorks FTT-10A Free Topology Transceiver User's Guide</i> , published by Echelon Corporation. It provides specifications and user instructions for the FTT-10A Free Topology Transceiver.		

Compatibility

The DXU-3 is compatible with the LCI-2 operator interface and will NOT operate with the LCI-1.

- 1) All Settings or description are valid for DXU3 v1.0x only
- 2) All Setting or descriptions are valid for DXU4 v1.0x only

Applications

Description for the single zone DX unit

The controller maintains the temperature of a space to a user-defined setpoint. Figure 1 ,2, 3 and 4 illustrate typical controller applications. The control is achieved by controlling the economizer position and sequencing the heating and cooling stages or modulating heating or cooling valves based on the current space requirements.

Figure 1: Single Zone DXU3 with staged heating and cooling and Modulated Economizer

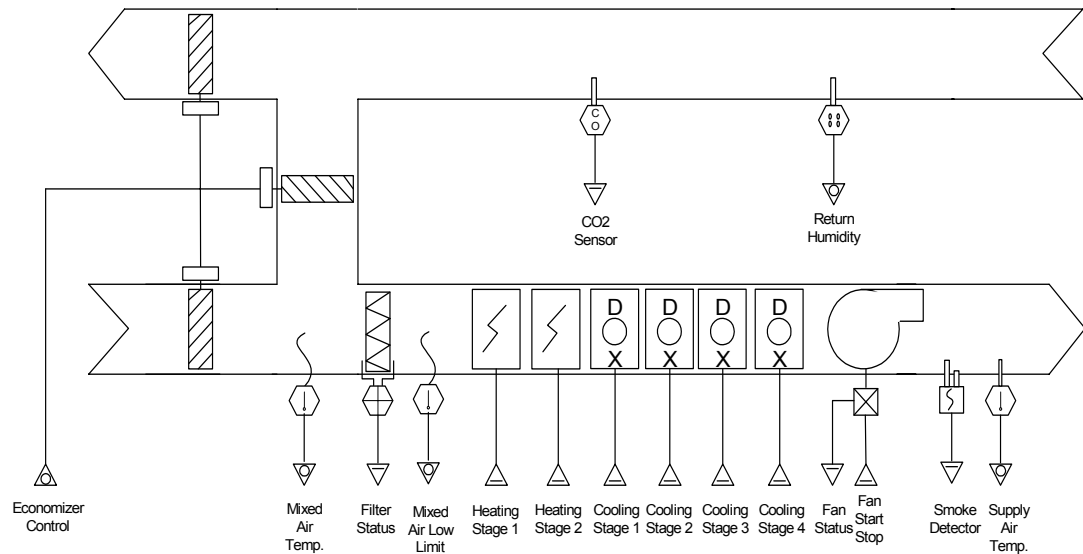
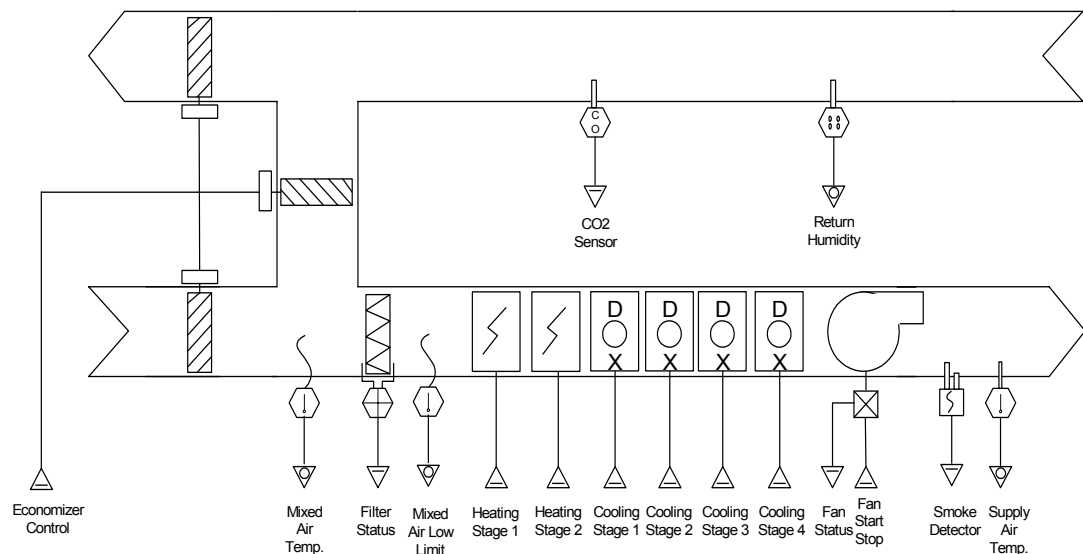

Figure 2: Single Zone DXU-3 with staged heating and cooling and Two Position Economizer¹⁾



The controller controls the starting and stopping of the supply air fan. The fan is energized when there is a need for heating or cooling. During the occupied periods, the fan can be configured to run continuously. The fan can be overridden from the local thermostat. If overridden, the fan runs continuously.

The enthalpies of the outside and inside air are calculated periodically. A comparison is performed to determine if “free cooling” is available. If “free cooling” is available, the economizer is enabled. Free cooling can also be enabled based on a dry-bulb comparison of the outdoor air temperature and indoor temperature. The system can use either a two position or modulated economizer. If a two position

economizer is employed, it is energized when there is a call for cooling. It is used as the first stage of cooling to take advantage of the energy savings. The two-position economizer output is off when the economizer feature is disabled.

If a modulated economizer is employed, when “free cooling” is available, the modulated economizer position is calculated by a Proportional + Integral (P+I) control loop. The control is based on the mixed air temperature and setpoint. As the temperature increases above the mixed air setpoint, the economizer valve is modulated open. The economizer is modulated closed as the temperature decreases below the mixed air setpoint. The economizer is modulated to its minimum position when the economizer is disabled. The economizer can optionally be disabled during unoccupied periods. When free cooling is available, mechanical cooling will not be enabled until the economizer is fully open (100%) for three minutes.

Heating is accomplished through control of up to two stages of electric heating, control of one floating point heating valve or control of one analog valve. Cooling is accomplished through control of up to four stages of cooling, one floating point cooling valve or control of one analog cooling valve.

The heating and cooling stages are sequenced with a time-proportioned control algorithm to minimize excessive cycling. The sequencing is based on the measured space temperature, space setpoint and the heating and cooling offsets. The heating and cooling offsets define a desired temperature range for occupied operation around the space setpoint. When unoccupied mode is entered, the heating setpoint is set back and the cooling setpoint is setup to a user-defined setpoint. The cooling stages are interlocked with the economizer control. If the two position economizer is employed, the stages sequence on after the economizer.

If configured for modulated analog valve the cooling valve position is calculated by a Proportional + Integral control loop based on the space temperature and the cooling setpoint. As the temperature increases above the cooling setpoint, the cooling valve will be modulated open. The cooling valve will be modulated closed as the temperature decreases below the cooling setpoint. When unoccupied mode is entered, the cooling setpoint is setup.

Figure 3: Single Zone DXU-3/4 with Modulated Heating, Cooling and Economizer

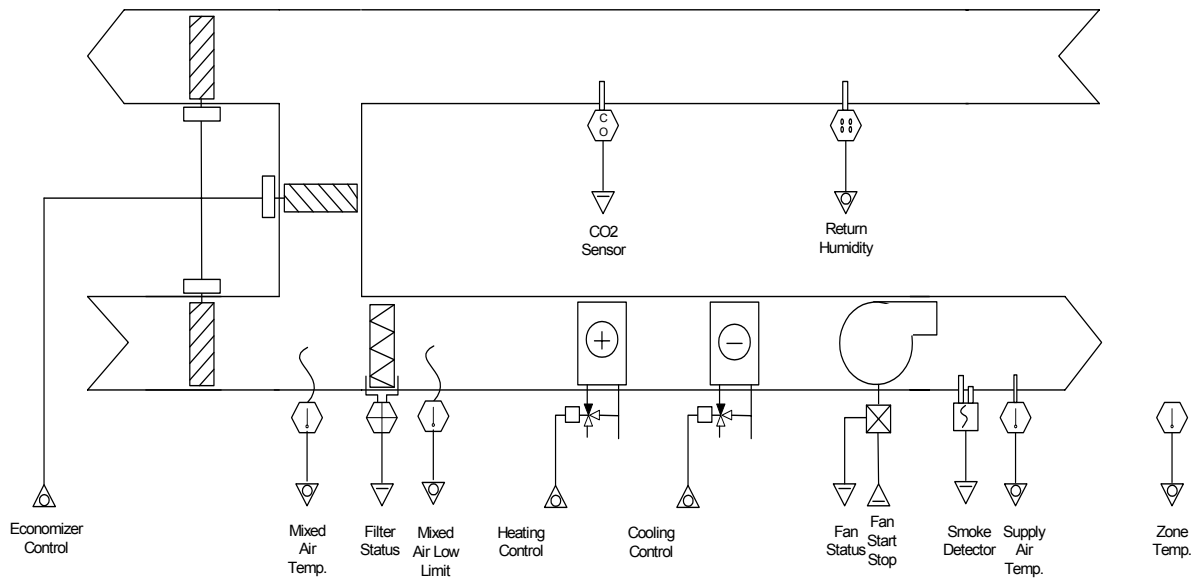

The heating valve position is calculated by a Proportional + Integral control loop based on the space temperature and the heating setpoint. As the temperature decreases below the heating setpoint, the heating valve will be modulated open. The heating valve will be modulated closed as the temperature increases above the heating setpoint. When unoccupied mode is entered, the heating setpoint is set back.

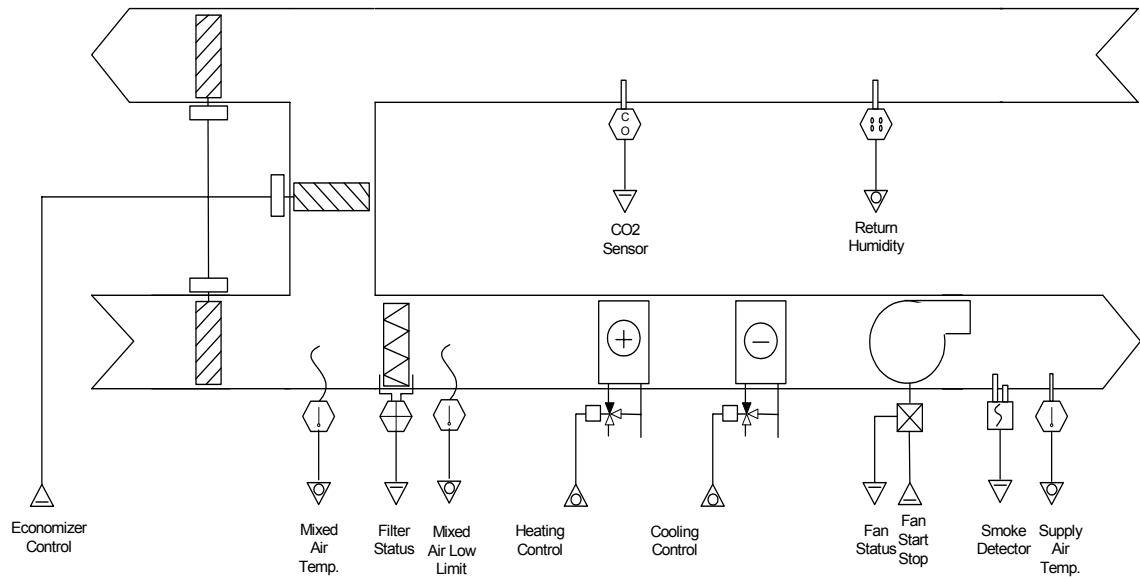
Figure 4: Single Zone DXU-3 with Modulated Heating, Cooling and Two-Position Economizer¹⁾

If configured for a floating point valve control the cooling valve is calculated by a Proportional + Integral control loop based on the space temperature and cooling setpoint. As the temperature increases above the cooling setpoint, the valve will be modulated open. The valve will be modulated closed as the temperature decreases below the cooling setpoint. When unoccupied mode is entered, the cooling setpoint is setup.

If configured for a floating point valve control the heating valve is calculated by a Proportional + Integral control loop based on the space temperature and heating setpoint. As the temperature decreases below the heating setpoint, the valve will be modulated open. The valve will be modulated closed as the temperature increases above the heating setpoint. When unoccupied mode is entered, the heating setpoint is setup.

Each controller interfaces to a local thermostat. The thermostat includes a space temperature sensor, temperature setpoint adjustment, occupancy override, and a fan auto/on selection (depending on the model). Additionally a 10K Precon Type II or Type III Thermistor/ wall sensor can be used.

The controller operates in one of two states: occupied or unoccupied. The LCI determines the active operating mode. The controller maintains the comfort level to a user-defined setpoint during the occupied period. The controller uses setup and setback values during the unoccupied period to maintain the space temperature. An optional backup schedule is provided for cases when the LCI is not available.

A digital input is provided to monitor the status of the supply air fan. If the fan is energized and no air flow is detected after 30 seconds, the controller turns off all stages of heating and cooling along with the supply air fan. The controller returns to normal operation after it is reset. An alarm is reported to the LCI when this condition exists.

The controller monitors a digital input to determine the presence of smoke. When the input indicates smoke, the controller immediately turns off the supply air fan and all stages of heating and cooling. The controller returns to normal operation after it is reset. An alarm is reported to the LCI when smoke is detected.

A digital input is provided on the controller to monitor the status of the air filter. An external pressure switch is wired to the input to determine when the filter becomes dirty. An alarm is reported to the LCI

when this condition exists.

Mixed air low limit protection is provided through a digital input. If a low limit condition exists, the controller turns off all stages of heating and cooling along with the supply air fan. An alarm is reported to the LCI when this condition exists. If configured for either analog or floating point valve the valve will open 100% to prevent freezing of the coils. The controller returns to normal operation after it is reset. Following the reset, there is a 10 minute delay before the mixed air low limit is checked again.

An indoor air quality input is provided. If an indoor air quality alarm is indicated, the supply air fan is energized and the economizer is overridden to supply fresh air to the space.

The controller monitors the runtime of the cooling stages, heating stages, and fan. When any of the runtimes exceeds a programmable limit, a maintenance alarm is reported to the LCI.

When the space temperature exceeds a programmable limit, a high limit alarm is reported to the LCI. When the space temperature drops below a programmable limit, a low limit alarm is reported to the LCI. When the space temperature returns to the proper range, a return to normal alarm is reported to the LCI.

When the return Air humidity rises above the humidity setpoint, dehumidification is enabled by enabling the cooling stages, if modulated cooling is enabled, the cooling output goes to 100%. Dehumidification is disabled, when return air humidity drops below the setpoint by 3%.

Sequence of Operation

This section describes the detailed sequence of operation for the controller control algorithms.

Setpoints

The heating and cooling setpoint for both occupied and unoccupied periods are programmable values. The space setpoint is a programmed value. The heating setpoint, and cooling setpoint are calculated from the space setpoint and heating and cooling offsets and the current operating mode (i.e. occupied or unoccupied).

The space setpoint is displayed in the thermostat and the LCI's controllers list.

The zero energy band is calculated as follows:

Occupied Mode

$$ZebOcc = (SpaceSetpoint - Heatoffset) - (SpaceSetpoint + CoolOffset)$$

Unoccupied Mode

$$\text{CalcHeatSp} = \text{UnoccupiedHeatSp}$$

$$\text{CalcCoolSp} = \text{UnoccupiedCoolSp}$$

Figure 5: Space Setpoint Calculation.

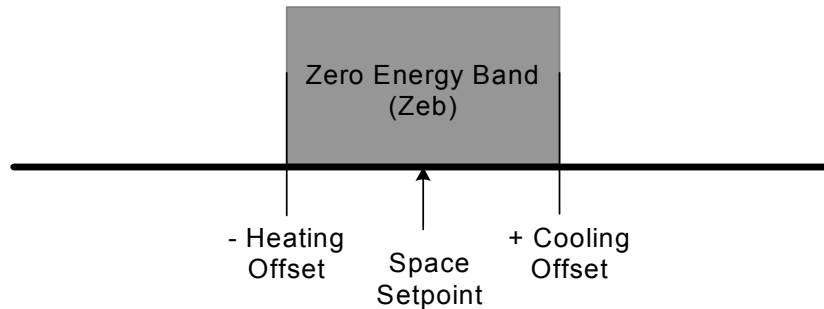

The effective setpoint is a calculated value based on the space setpoint and the thermostat *setpoint adjust limit* value. The *setpoint adjust limit* is used to increase or decrease the space setpoint from the local thermostat. The *setpoint adjust limit* value limited to plus or minus the programmed setpoint adjustment.

The *setpoint adjust limit* also affects the calculated heating and calculated cooling setpoints by an equal amount. The *setpoint adjust limit* only applies in the occupied mode of operation. It has no affect in the unoccupied mode. Note that the actual programmed setpoint, heating and cooling offsets are not changed. The thermostat *setpoint adjust limit* is simply added to the programmed setpoints to derive the calculated values.

Occupied Mode

$$\text{CalcCoolingSp} = \text{SpaceSp} + \text{CoolOffset} \pm \text{UserAdjust}$$

$$\text{CalcHeatingSp} = \text{SpaceSp} - \text{HeatOffset} \pm \text{UserAdjust}$$

$$\text{EffectiveSp} = \text{SpaceSp} \pm \text{SpOffset}$$

Unoccupied Mode

$$CalcCoolingSp = UnoccupiedCoolingSp$$

$$CalcHeatingSp = UnoccupiedHeatingSp$$

$$EffectiveSp = SpaceSp$$

Figure 6: Setpoint Adjustment

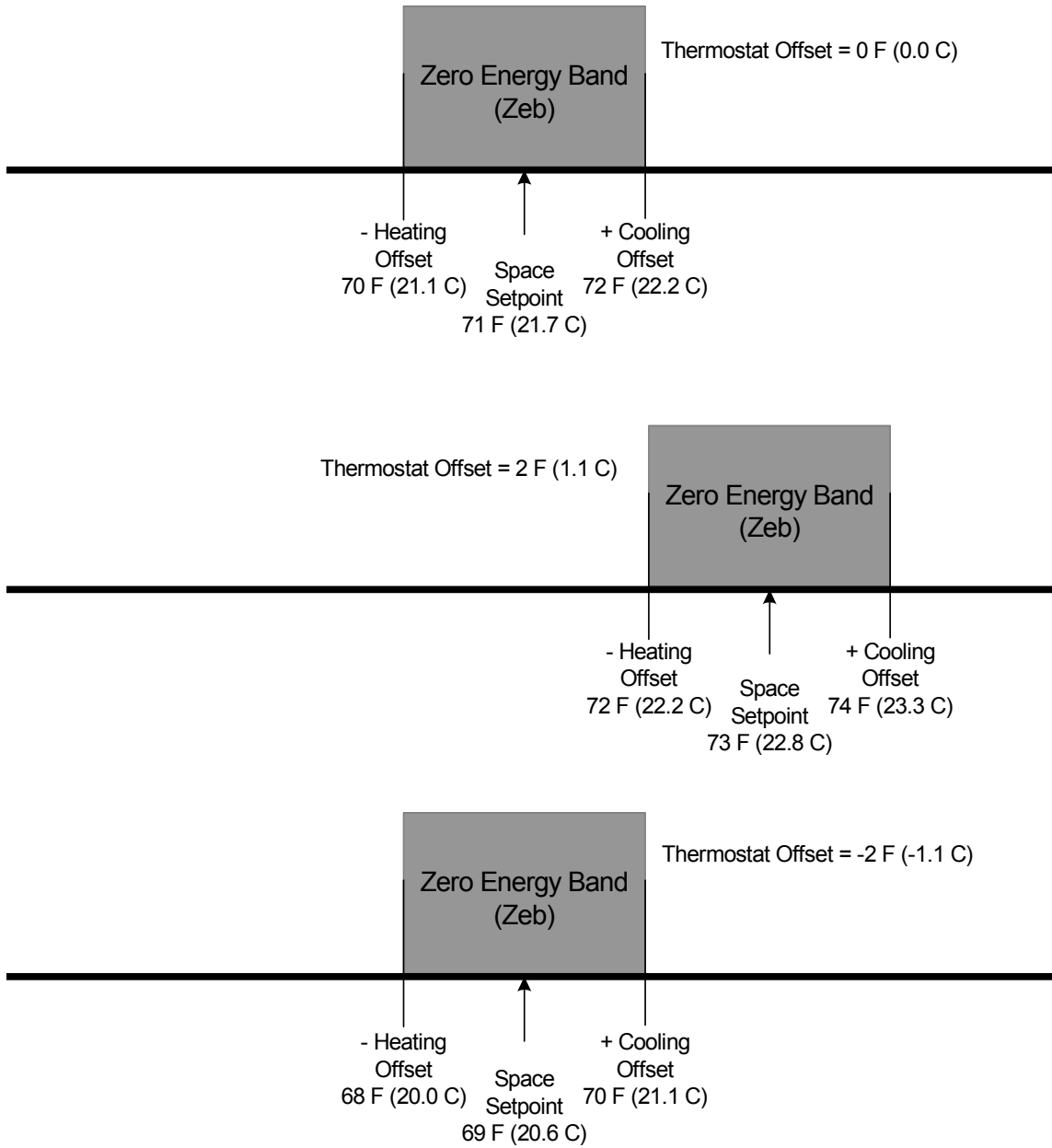

Heating Sequence

The controller provides support for either two stages of electric heating or one floating point or 0 - 10V modulating heating valve. You can specify which type of heat you are using through configuration parameters.

Heating Stages

The controller sequences the electric heating stages based on the space temperature and the calculated heating setpoint. When the space temperature drops below the heating setpoint minus the heating control band for a predefined time-period, a stage is turned on. If the space temperature remains below this value for an additional time-period, the next available stage is turned on. This cycle continues until all available stages have been energized.

After the space temperature has risen above the heating setpoint for a predefined period of time, the last energized stage is turned off. (Note that the last stage that was turned on is the first one to be turned off.) If the space temperature remains above the heating setpoint for an additional time-period, the next previous stage is turned off. This cycle continues until all stages have been de-energized.

When the space temperature rises above the space setpoint, all of the electric heating stages turns off.

During unoccupied periods, the heating setpoint is adjusted downwards using a separate unoccupied heating setpoint.

Figure 7: Heat Sequence - Occupied Mode

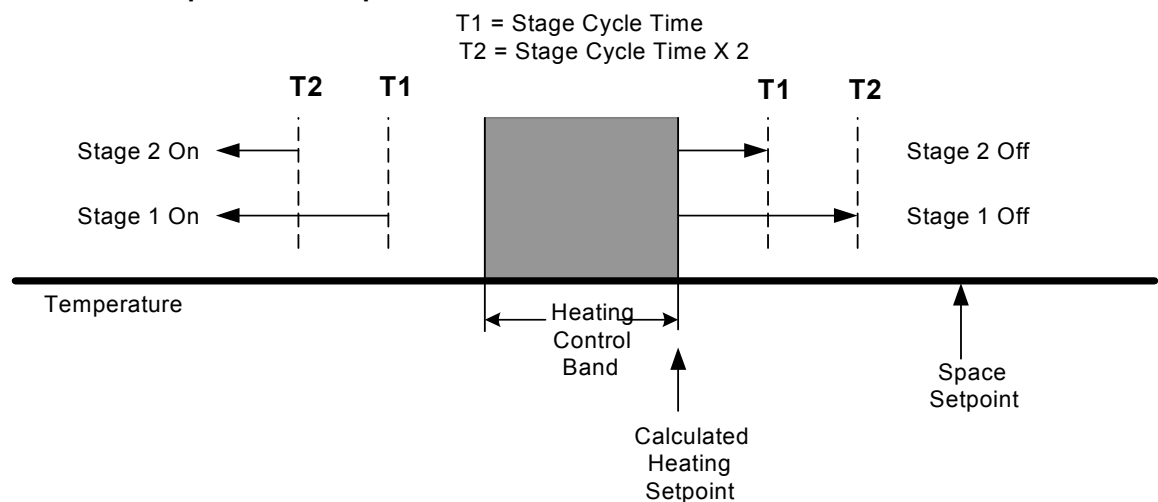
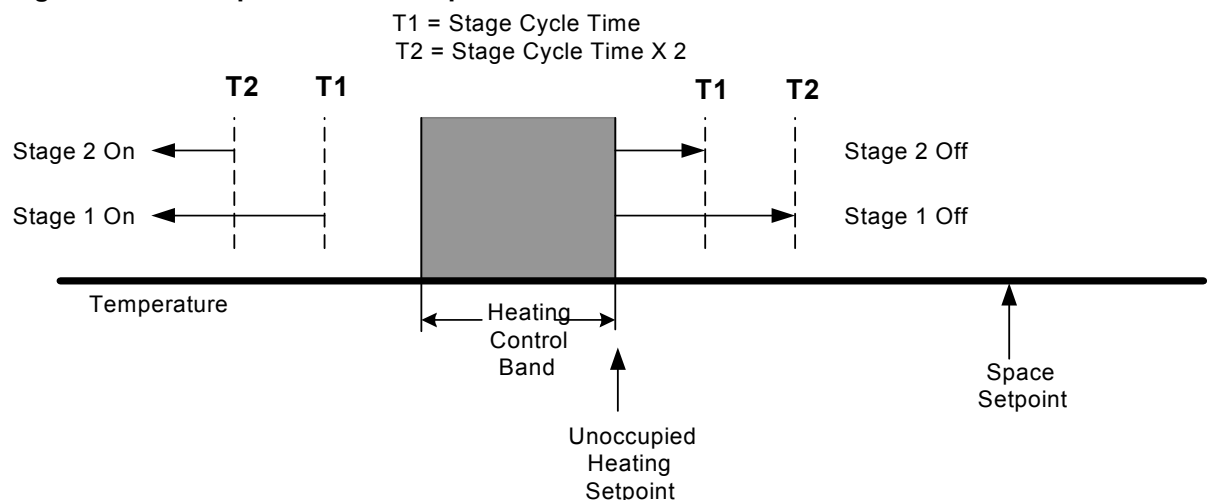
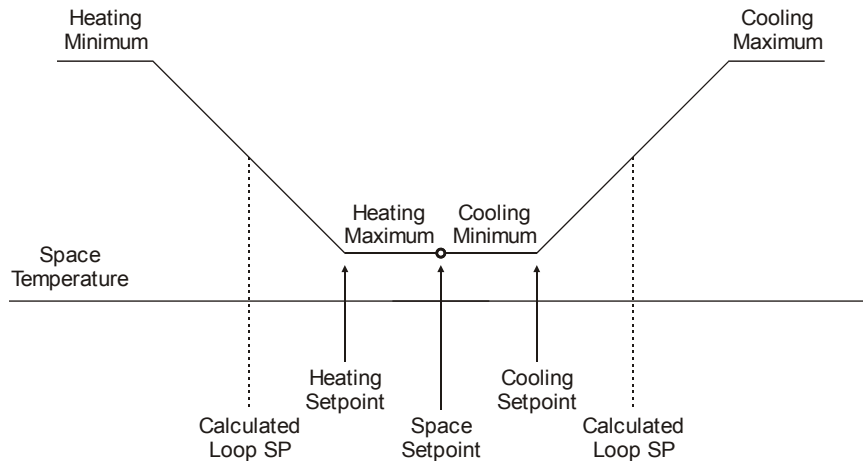

Figure 8: Heat Sequence - Unoccupied Mode



Heating Valve control



Heating with Floating Point Control

The heating stage outputs can be configured for floating point control of a heating valve. Floating point control is enabled when *Heating Stages* are set to zero and the *Heating Valve Travel Time* is non-zero. The H1(TO2) output is the valve open signal and the H2(TO3) output is the valve close signal.

After a reset, the floating point valve is calibrated by closing the valve for a period of the travel time. This ensures that the valve is fully closed. When the valve is at its calculated 0% or 100% position, the valve is overdriven for 30 seconds to ensure that the valve is fully closed or open.

The floating point control is similar to the heating modulated algorithm. If the space temperature is below the heating setpoint, the valve is driven open. When the space temperature is above the heating setpoint, the valve is driven close. There is a +/- 1 °F (0.55 °C) deadband around the setpoint to prevent the valve from dithering. During mixed air low limit alarms, the heating valve is driven to 100%.

During unoccupied periods, the heating setpoint is adjusted downwards using a separate unoccupied heating setpoint.

Heating with Modulated heating valve

The *calculated heating loop setpoint* is derived from the heating setpoint and the loop proportional gain.

$$CalcHeatingLoopSp = CalcHeatingSp - \frac{1}{2(K_p)}$$

The heating valve is modulated by a Proportional + Integral (P+I) control loop based on the heating loop setpoint and the space temperature. The P+I control loop will modulate the valve to maintain a constant space temperature. As the temperature decreases below the heating loop setpoint, the heating valve will be modulated open. The heating valve will be modulated closed as the temperature increases above the heating loop setpoint. When unoccupied mode is entered, the heating loop setpoint is set back through a separate unoccupied heating setpoint.

To prevent the integral component from becoming too large, there is anti-wind up reset protection. This protection clamps the integral value when all of the components add up to more than 100% or less than 0%. The following equations are used for P+I control:

$$K_p = \text{Proportional Gain}$$

$$K_i = \text{Integral Gain}$$

$$\text{Error} = \text{HeatingLoopSp} - \text{SpaceTemp}$$

$$I = I + (K_i \times \text{Error})$$

$$\text{HeatPosition} = (K_p \times \text{Error}) + I$$

Cooling Sequence

Cooling stages

The controller sequences the cooling compressor stages based on the space temperature and the calculated cooling setpoint. When the space temperature rises above the cooling setpoint plus the cooling control band for a predefined time-period, a stage is turned on. If the space temperature remains above this value for an additional time-period, the next stage is turned on. This cycle continues until all stages have been energized. The DXU-3 can control up to 4 stages, DXU-4 can control up to 2 stages.

In order to provide maximum energy savings, the cooling stages are interlocked with the economizer. When the economizer is enabled, the cooling stages are prevented from energizing before the economizer has reached its maximum position for 3 minutes.

After the space temperature has dropped below the cooling setpoint for a predefined time-period, the last-energized stage is turned off. (Note that the last stage that was turned on is the first one to be turned off.) If the space temperature remains below the cooling setpoint for an additional time-period, the next previous stage is turned off. This cycle continues until all stages have been de-energized.

When the space temperature drops below the space setpoint, all of the cooling stages turns off.

During unoccupied periods, the cooling setpoint is adjusted upwards using a separate unoccupied cooling setpoint.

Figure 9: Cooling Sequence - Occupied Mode

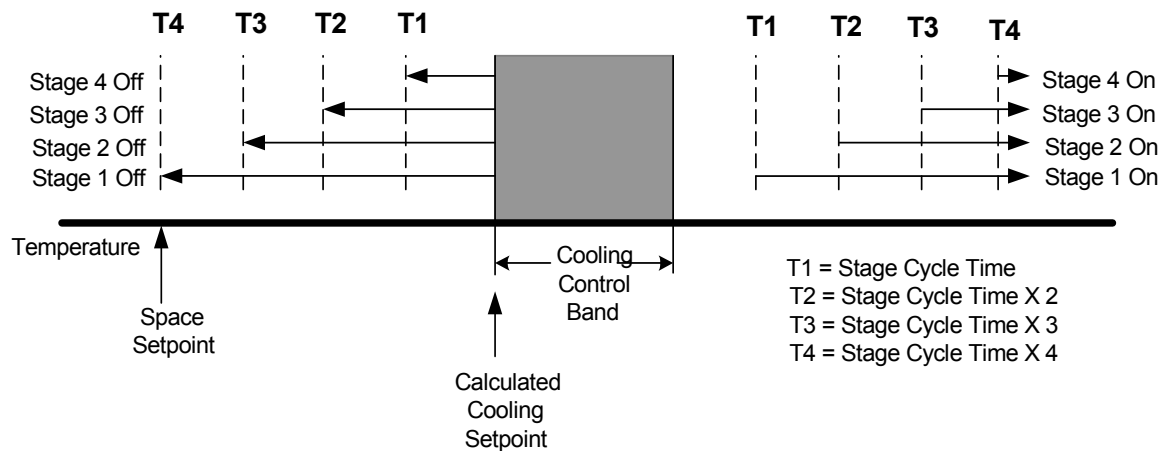
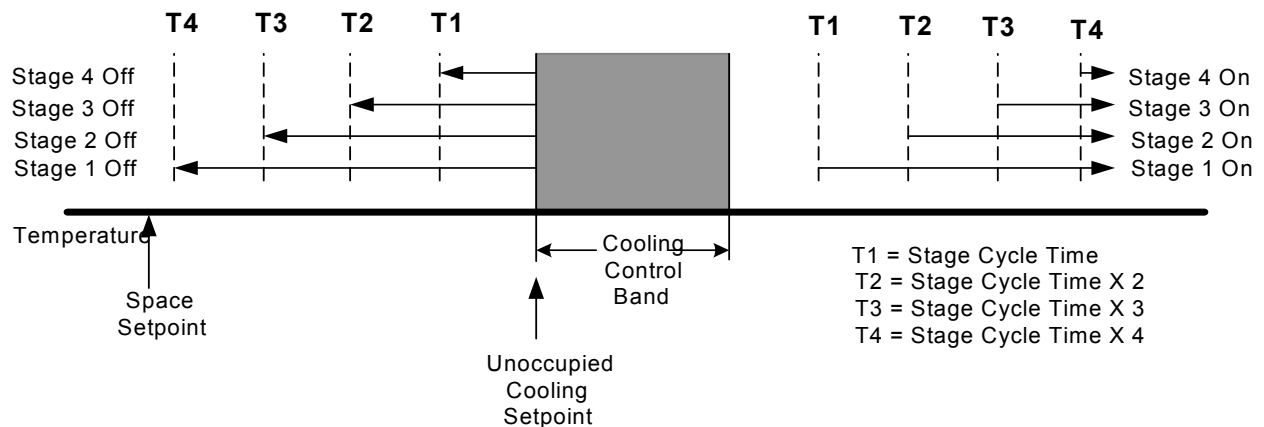
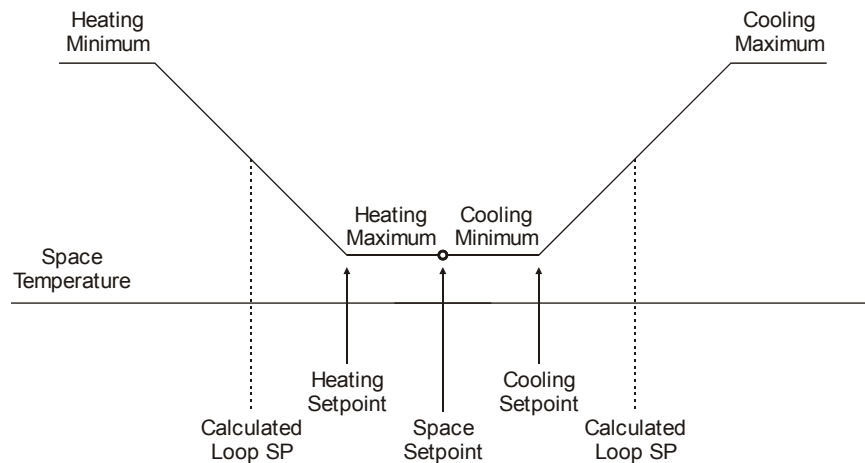

Figure 10: Cooling Sequence – Unoccupied Mode



Cooling Valve Control



Cooling with Floating Point Control

The first two cooling stage outputs can be configured for floating point control of a cooling valve. Floating point control is enabled when *Cooling Stages* are set to zero and the *Cooling Valve Travel Time* is non-zero. The C1(TO4) output is the valve open signal and the C2(TO5) output is the valve close signal.

After a reset, the floating point valve is calibrated by closing the valve for a period of the travel time. This ensures that the valve is fully closed. When the valve is at its calculated 0% or 100% position, the valve is overdriven for 30 seconds to ensure that the valve is fully closed or open.

The floating point control is similar to the cooling modulated algorithm. If the space temperature is above the cooling setpoint, the valve is driven open. When the space temperature is below the cooling setpoint, the valve is driven close. There is a +/- 1 °F (0.55 °C) deadband around the setpoint to prevent the valve from dithering. During mixed air low limit alarms, the cooling valve is driven to 100%.

During unoccupied periods, the cooling setpoint is adjusted downwards using a separate unoccupied cooling setpoint.

Cooling with modulated cooling valve

The *calculated cooling loop setpoint* is derived from the calculated cooling setpoint and the loop proportional gain.

$$CalcCoolingLoopSp = CalcCoolingSp + \frac{1}{2(K_p)}$$

The cooling valve is modulated by Proportional + Integral (P+I) control loop based on the cooling loop setpoint and space temperature. The P+I control loop will modulate the valve to maintain a constant space temperature. As the temperature increases above the cooling loop setpoint, the cooling valve will be modulated open. The cooling valve will be modulated closed as the temperature decreases below the cooling loop setpoint. When unoccupied mode is entered, the cooling setpoint is setup through a separate unoccupied cooling setpoint.

To prevent the integral component from becoming too large, there is anti-wind up reset protection. This protection clamps the integral value when all of the components add up to more than 100% or less than 0%. The following equations are used for P+I control:

$$K_p = ProportionalGain$$

$$K_i = IntegralGain$$

$$Error = CoolingSetpoint - SpaceTemp$$

$$I = I + (K_i \times Error)$$

$$CoolPosition = (K_p \times Error) + I$$

Economizer Operation

The controller provides support for either two-position or modulated economizer types. You can specify which type of economizer you are using through a configuration parameter. Both economizer types are enabled based on the availability of “free cooling” from the outdoor air. Free cooling can be determined by dry bulb or enthalpy comparisons. In order to provide maximum energy savings, the cooling stages are interlocked with the economizer.

Dry Bulb Comparisons

Free cooling can be determined based on a comparison of outdoor air temperature and indoor air temperature. When the outdoor air temperature is a programmable amount below the indoor air temperature, free cooling is enabled. When the outdoor air temperature rises above the indoor temperature, free cooling is disabled.

Enthalpy Comparison

An enthalpy calculation is performed periodically to determine if “free cooling” is available from the outside air. The outside enthalpy is calculated based on the outside air temperature and humidity. The outside temperature and humidity are measured by an external device (such as an ASM) on the network and sent to the controller. The same calculation is performed on the inside air based on the space temperature and return air humidity. The inside enthalpy minus the outside enthalpy must be greater than the Free Cooling Setpoint in order for the economizer to be used for free cooling.

Optionally, an ASM can measure the indoor air humidity globally. In this case, a return air humidity sensor would not be required at each DXU-3/4.

Two-position Economizer Control¹⁾

If present, the two-position economizer is enabled when there is “free cooling” available as determined by the enthalpy or drybulb calculations. When the economizer is enabled, the economizer triac output is energized. When the economizer is disabled, the economizer output is de-energized. A configuration parameter is available to optionally disable the economizer during unoccupied periods.

Modulated Economizer Control

If present, the modulated economizer is enabled when there is “free cooling” available as determined by the enthalpy or drybulb calculations.

Figure 11: Economizer Control.

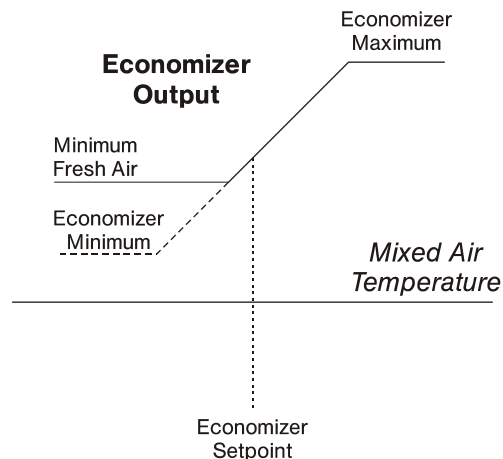

When the economizer is enabled, a Proportional + Integral (P+I) control loop modulates the economizer output position to maintain a constant mixed air temperature

The Proportional + Integral (P+I) control loop is based on the mixed air temperature setpoint and economizer setpoint. As the temperature increases above the economizer setpoint, the economizer is modulated open. The economizer is modulated closed as the temperature decreases below the economizer setpoint.

To prevent the integral component from becoming too large, there is anti-wind up reset protection. This protection clamps the integral value when all of the components add up to more than 100% or less than 0%. The following equations are used for P+I control:

$$K_p = \text{ProportionalGain}$$

$$K_i = \text{IntegralGain}$$

$$\text{Error} = \text{EconSp} - \text{MixedAirTemp}$$

$$I = I + (K_i \times \text{Error})$$

$$\text{EconPosition} = (K_p \times \text{Error}) + I$$

When the economizer is disabled, it modulates to the minimum position. A configuration parameter is available to optionally disable the economizer during unoccupied periods.

Cutoff Temperatures

The cutoff temperatures can be set for heating, cooling and for the economizer to suppress mechanical equipment from activating if the Outside Air Temperature is above or below a certain setting.

Heating will be suspended, when the Outside Air Temperature rises above *Max OAT Heat* and resumes, when the OAT falls 5 °F. Cooling is suspended, when the Outside Air Temperature falls below *Min OAT Cool* and will resume, when OAT rises 5 °F. The Economizer will close the Dampers to the *MinAirPosition*, whenever the Outside Air Temperature is outside the *Max OAT Econ* and *Min OAT Econ* Temperature limits.

The cutoff temperatures will remain inactive as long as their value is equal or below 0°F.

Dehumidification

If the *Setpoint* is set to zero, dehumidification is disabled. When the humidity is above the *Setpoint* dehumidification begins and stops when the humidity drops below *Setpoint* - 3%.

There are three types of Dehumidification *Normal*¹⁾, *with Reheat*²⁾ or *with Heat*²⁾.

In *Normal* mode Dehumidification stops, when the Space Temperature drops below the Heating Setpoint minus Shutoff offset. Dehumidification is disabled, when the unit is in Heating

Dehumidification with Reheat means, that a floating point valve is modulated to drive an external reheat element. Cooling and reheating can occur at the same time.

The floating point reheat valve uses triac outputs 3 and 4 to modulate the valves. Output 3 opens the valve and output 4 closes the valve.

***Dehumidification with Heat* expects the heating coil placed downstream the cooling coil in the duct.** Cooling and heating will then operate at the same time, where the heating coil will heat up the air that was previously cooled down according to the setpoints.

During Dehumidification, the operating mode will be displayed as Dehumid, the cooling outputs will stage on and the stage timer is enforced, or modulating output or floating point valve will be set to 100%.

Fan Operation

During occupied periods, you can set the fan to always run or to cycle off when the space temperature is within the zero energy band. The zero energy band is defined as the temperature range between the cooling and heating setpoints. The fan is interlocked with the cooling and heating stages. If there is a call for heating or cooling, the fan energizes. During the unoccupied period, the fan always cycles off when the space temperature is within the zero energy band.

Depending on the model of thermostat, you may be able to override the fan from the local thermostat. When the fan selection is set to *Auto*, the fan operates as described above. If the fan selection is set to *On*, the fan is constantly on. When the fan type is set to “Auto No heat” the fan will not operate, when in heating mode. This is typical for residential units. When the fan type is “Auto with Radiant” the fan will not operate until the second stage of heat is turned on.

Humidification²⁾

If the Setpoint for Low Limit is not set to zero humidification will be enforced. The Indoor Air Humidity or Return Air Humidity will be compared to the *Humid Setpoint Low*. If it is below the setpoint, humidification is turned on.

To protect the duct from accumulating too much moisture a *Humid Setpoint High* can be enforced. A humidity sensor placed in the discharge air duct segment and wired into an ASM2 module Indoor Air input, provides the humidity that will be compared to the *Humid Setpoint High*. When the Discharge Air Humidity exceeds the limit, Humidification will be shut off even if the Indoor Air Humidity or the Return Air Humidity should be below the *Humid Setpoint Low*.

A 1% deadband around the setpoints prevents short cycling of the equipment.

The humidifier uses triac output 8²⁾. There is no digital economizer available in DXU-4 v1.xx. The humidifier replaces the digital economizer function.

Fan Proof

When there is a call for heating or cooling, the fan output is energized. A fan status input is provided for monitoring the operation of the fan. When the fan is initially turned on, there is a 30 second delay before the fan status is checked. If at any time after the delay, the fan status indicates the fan is not running, a fan failure condition is generated. The heating and cooling stages are interlocked with the fan. When a fan failure condition exists, the heating stages, cooling stages and the fan immediately turn off. The controller must be reset to clear this condition.

Note: If you are not providing a fan status switch, the input must be jumpered to the adjacent common. After a fan failure, the controller’s status LED goes solid red. To return the controller to normal operation after the failure condition is resolved, you must reset the controller by removing and reapplying power or by using the controller reset feature on the LCI. (See *iWorX LCI User’s Guide* for details.)

Smoke Detection

A smoke detector input is provided. If the smoke detector indicates smoke is present, all of the stages and the fan turn off. The controller returns to normal operation after a reset.

Mixed Air Low Limit Detection

An input is provided for a mixed air low limit detection device. If a low limit condition is detected, all of the stages and the fan turn off. The controller returns to normal operation after a neuron reset. (After the DXU-3/4 switches from unoccupied mode to occupied mode, there is a ten minute delay before it reports Mixed Air Low Limit alarms.) If heating is configured as modulated or floating point the heating valve opens to 100%

Filter Status

The filter status input is monitored to determine if the filter is operating properly. The input is used to indicate that maintenance is required on the filter. The controller application is not shutdown due to a filter alarm.

Indoor Air Quality

An indoor air quality input is provided. If an indoor air quality alarm is indicated, the supply air fan is energized and the economizer is overridden to supply fresh air to the space.

The source of an indoor air quality signal can be a digital sensor providing an on/off signal or a configurable analog sensor. Setup of the analog sensor requires the IAQ sensor settings to be populated. A Min, Max, Setpoint and an Offset can be specified. When an indoor air condition is sensed by the controller, the economizer is opened to 100%.

The DXU-3 has a temperature reset function for IAQ alarm operation. The temperature reset function allows the space temperature to rise above or drop below the calculated control setpoints by a configurable amount. This feature allows time for indoor air quality to improve. During IAQ Alarm operation, if the space temperature rises above or drops below the temperature reset limit, the DXU-3 will resume normal economizer control to maintain a comfort space temperature. Once the space temperature is brought within the calculated setpoints and an IAQ Alarm condition still exists, the DXU-3 will resume the IAQ mode of operation.

The DXU-3 has an alarm delay function that configures how long it will wait before signalling an IAQ Alarm condition.

Thermostat

The space temperature value, setpoint adjustment, fan auto/on status (depending on the thermostat model), and occupancy override request are monitored by the thermostat and sent to the controller.

The controller automatically detects a failure of the thermostat. When the thermostat fails, the cooling stages, heating stages, economizer, and fan are turned off and control is disabled.

Note: Unless another host controller overrides the space temperature through the LCI, the thermostat must be connected. The status LED on the controller turns solid red if the thermostat is not connected and no other controller is providing temperature data. Once the DXU-3/4 begins receiving temperature data, the status LED turns green indicating normal operation.

Extended Occupancy Time accumulation

When the space is overridden to the occupied mode of operation via the space thermostat, the amount of extended occupancy is accumulated. The extended occupancy time is accumulated in minutes and can be viewed from the LCI under the "Thermostat Settings".

The extended occupancy time is backed up to non-volatile memory at midnight. The user can clear the accumulated extended occupancy from the LCI.

Local Backup Schedule

The LCI normally determines the operating mode. You can define a local backup schedule for situations when the LCI is not available. When the controller detects that the LCI is not available (after 10 minutes without communication), it resorts to the local backup schedule that you have configured. If the local backup schedule is disabled, the controller defaults to the occupied mode.

You configure the occupied and unoccupied times that are used in determining the current operating mode of the controller when it is running the backup schedule. By default, both the unoccupied and occupied time are set to zero, which disables the local backup schedule. This causes the controller to default to the occupied mode of operation if it cannot communicate with the LCI.

Runtime Accumulations

The total runtime is accumulated for the heating, cooling, and fan outputs. The runtimes can be used to indicate that maintenance is required on the equipment controlled by these outputs. The runtime can be reset by an operator or maintenance person once servicing has been performed.

Alarms and Events

The controller detects certain alarm conditions and sends them to the LCI. Before this can occur, you must use the LCI to configure the controller.

Digital Input Alarms

The controller monitors the status of the digital inputs and generates alarms for the following events:

- Fan failure (Fan Failed Alarm)
- Smoke detect (Smoke Detected Alarm)
- Mixed air low limit condition (Low Limit Alarm)
- Dirty filter (Dirty Filter Alarm)
- Indoor Air Quality (Indoor Air Quality Alarm)

Thermostat Failure

The controller automatically detects the presence of the local thermostat and monitors its status. If the thermostat fails to communicate with the controller, a Thermostat Failed Alarm is generated and the controller's status LED turns red. If the space temperature is overridden by a host controller, this alarm is disabled.

Maintenance Alarm

The controller provides programmable run limits for generating runtime Maintenance Alarms. When any of the cooling, heating, or fan runtime limits are exceeded, a Maintenance Alarm is sent to the LCI.

Space Temperature Alarms

The controller generates high and low limit alarms for the space temperature. You can configure a programmable space temperature alarm limit offset. The temperature limits are calculated based on the control setpoints, alarm limit offset, and control band.

$$HighLimit = CalcCoolingSp + AlarmLimitOffset + CoolBand$$

$$LowLimit = CalcHeatingSp - AlarmLimitOffset - HeatBand$$

When the measured space temperature exceeds the high limit, a high limit alarm (Space Temperature High Limit Alarm) is generated. When the space temperature drops below the low limit, a low limit alarm is generated (Space Temperature Low Limit Alarm). A return to normal alarm is generated when the space temperature is between the high and low limit (Space Temperature Return to Normal).

When the controller switches between the unoccupied and occupied modes of operation, no space temperature alarms are reported for 30 minutes following the switch. This helps eliminate nuisance alarms.

Automatic Configuration

The DXU-3/4 and iWorX Local Control Interface (LCI) use a self-configuring network management scheme requiring no external tools, binding, or LONWORKS knowledge. The LCI recognizes and configures the DXU-3/4 when the controller's service pin is pressed. The controller's status light flashes green until the controller is configured, and will be solid green after the controller is configured. Once the service pin has been pressed, no further action is required by the user; the controller is fully accessible to the LCI. Users may bind to SNVTs on the DXU-3/4 with LNS or other LONWORKS tools if they wish.

The LCI also provides network supervision of the DXU-3/4. The LCI periodically sends a "ping" message to the DXU-3/4, which elicits a response. If the response fails, an alarm is displayed on the LCI. The LCI also uses the "ping" message to refresh the occupancy mode and other system wide data.

DXU-3/4 Configuration

Once the DXU-3/4 is properly installed and recognized by the Local Control Interface (LCI), the LCI can be used to configure the settings of the controller. This section describes the commands available on the LCI for configuration of the DXU-3/4, and the meanings and suggested values for controller parameters. For more information on using the LCI, see the *iWorX LCI User's Guide*.

List All Settings

Displays all of the DXU-3/4's setpoints and editable settings and provides access to edit all DXU-3/4 parameters from a single screen, some of the parameters are structures and will be described in individual tables below this table..

Table 1: All DXU-3/4 Settings

Setting	Range	Default	Description
CM1 Status		Structure	Type of board (small, med, large)
Thermostat		Structure	Thermostat Settings
Setpoints		Structure	Setpoint Settings
Staged Cooling		Structure	Staged Cooling Settings
Modulated Cooling		Structure	Modulated Cooling Settings
Floating Setpoint Cooling		Structure	Floating Point Valve Cooling Settings
Staged Heating		Structure	Staged heating Settings
Modulated Heating		Structure	Modulated heating Settings
Floating Setpoint Heating		Structure	Floating Point Valve heating Settings
Fan Type	Auto, On, Auto no Heat ²⁾ , Auto w/ Radiant ²⁾	Auto	Set to "On" to enable continuous operation during occupied mode. Otherwise, fan switches on and off automatically according to the control algorithm, "Auto no Heat" is used for residential Apps, where the furnace controls the fan, "Auto w/ Radiant" has no fan in stage one
Economizer		Structure	Economizer settings
Free Cooling		Structure	Free Cooling settings
Dehumidification		Structure	Dehumidification Settings
Floating SP Dehumid ²⁾		Structure	Floating Point Valve Reheat during Dehumidification Settings
Dehumid Type ²⁾	Normal, With Reheat, With Heat	Normal	See Top. Dehumidification
Runtime Limits			Runtime Limit Settings
Backup Occ Time			
– Hours	0 to 23	0	Time to begin occupied period for the local backup schedule.
– Minutes	0 to 59	0	

Table 1: All DXU-3/4 Settings (Continued)

Setting	Range	Default	Description
Backup Unocc Time			
– Hours	0 to 23	0	Time to end occupied period for the local backup schedule.
– Minutes	0 to 59	0	
Demand group			Demand Limit Group
IAQ Mode	Digital, Analog	Digital	Type of IAQ Sensor
IAQ Settings		Structure	Setting for the IAQ Alarm
IAQ Sensor		Structure	Settings for the IAQ analog Sensor
OAT Cutoff		Structure	Provides entries for cutoff temperatures for heating, cooling and economizer functions
Humid Setpoint Low	0 - 100%	0%	0% means Humidification is disabled, any other value enforces Humidification, when the IndoorRH or the ReturnRH is below limit
Humid Setpoint High	0 - 100%	80%	DischargeRH not to exceed High Limit or Humidification will be shutt off

²⁾ Settings only in DXU-4 Version 1.0x

CM1 Status

Table 2: Status of certain board specific variables

Settings	Range	Default	
Board type		Structure	Type of board (small, med, large)
Code type			Type of software (small, med, large)
Software build			Software Build Number
Microset II versio			Microset II version
Space humidity		0.00% or 100.00%	Space Humidity (from MS2)
Microtouch setpoint			Setpoint (from Microtouch)
Comm errors			Communication Errors

Thermostat Settings

Table 3: DXU-3 Thermostat Setting

Setting	Range	Default	Description
Type	Microset2, MicroTouch, PreconIII, PreconII, Not used	Microset2	Type of Thermostat used
Occupancy Extension	0 to 1000 minutes	60 minutes	Allowable occupancy extension time.
Alarm Temperature offset	0 - 10.0 °F	5 °F	Degrees below the heating setpoint or above the cooling setpoint to trigger a low limit or high limit alarm. Zero disables the alarm
Temperature offset	-10.0 - 10.0 °F	0 °F	Degrees to be added or subtracted from the actual zone temperature. This setting is used as a means to calibrate the actual temperature reading.
Military Time	No, Yes	No	Set to "Yes" to display the time in a military format on the MicroSetII. Set to "No" to display the time in a 12 hour format on the Microset II display.
Field Service	No, Yes	Yes	"No" means no access to field service codes. "Yes" means acces to field service codes available.
Accumulated Ext time		0 Min	Accumulated occupancy extension time.

Setpoints

Table 4: DXU-3 Setpoint Settings

Settings	Range	Default	Description
Setpoint	50 to 95 °F (10 to 35 °C)	72.0°F (22.2 °C)	Setpoint for occupied time periods.
Cooling Offset	0 - 10.0 °F	1 °F	This value is used to calculate the cooling SP by adding to the SP
Heating Offset	0 - 10.0 °F	1 °F	This value is used to calculate the heating SP by subtracting from the SP
Setpoint Adjust Limit	0 - 10.0 °F	2 °F	Setpoint adjustment for occupied time periods.
Unoccupied Cooling Setpoint	50 to 95 °F (10 to 35 °C)	82.0°F (27.7 °C)	Cooling setpoint for unoccupied time periods.
Unoccupied Heating Setpoint	50 to 95 °F (10 to 35 °C)	60.0°F (15.5 °C)	Heating setpoint for unoccupied time periods

Heating / Cooling Settings

The following parameter structures display all the possible heating and cooling parameters used by the DXU-3/4 controller. Select the parameter to modify and then use the keypad to enter in the desired value. For drop down menus select the new value and then depress the save button. Press **Save** to save your changes or **Prev** to return to the Setup screen.

Table 5: DXU-3/4 Staged Cooling Settings

Setpoint	Range	Default	Description
Stages	0 to 4(2 ²)	4 ¹ ,2 ²)	Number of cooling stages controlled. Set to zero to disable cooling
Control Band	0 to 10 °F (0 to 5.56 °C)	1.0 °	Value used to modify the calculated heating and cooling setpoints to form the temperature range in which local heating or cooling is enabled.
Stage Time	0 to 255 minutes	5 minutes	The rate at which stages are sequenced.

Table 6: DXU-3 Modulated Cooling Settings

Setpoint	Range	Default	Description
Kp	0.00 to 100.00% per °F	5.00%	Proportional gain of the cooling P+I control loop.
Ki	0.00 to 100.00%	0.05%	Integral gain of the cooling P+I control loop.
Minimum AO Voltage	0.0 to 10.0 Volts	0.0 Volts	Minimum output voltage for modulated Cooling.
Maximum AO Voltage	0.0 to 10.0 Volts	10.0 Volts	Maximum output voltage for modulated Cooling. If set to 0 Modulation is disabled

Table 7: DXU-3 Floating Point Valve Cooling Settings

Setting	Range	Default	Description
Kp	0.00 to 100.00% per °F	5.00%	Proportional gain of the floating point valve's P+I control loop.
Ki	0.00 to 100.00%	0.05%	Integral gain of the floating point valve's P+I control loop.
Travel Time	0 to 600 seconds	0 seconds	Total time it takes for the floating point cooling valve to travel from fully closed to fully open. If set to 0, floating point valve is disabled
Deadband	0.00 to 100.00%	10%	The desired setpoint must be this far or greater from the actual position before modulating the actuator.

Table 8: DXU-2 Staged Heating Settings

Setting	Range	Default	Description
Stages	0 to 2	2	Number of heating stages controlled. Set to zero to disable heating
Control Band	0 to 10 °F (0 to 5.56 °C)	1.0 °	Value used to modify the calculated heating and cooling setpoints to form the temperature range in which local heating or cooling is enabled.
Stage Time	0 to 255 minutes	5 minutes	The rate at which stages are sequenced.

Table 9: DXU-3 Modulated Heating Settings

Setpoint	Range	Default	Description
Kp	0.00 to 100.00% per °F	5.00%	Proportional gain of the Heating P+I control loop.
Ki	0.00 to 100.00%	0.05%	Integral gain of the heating P+I control loop.
Minimum AO Voltage	0.0 to 10.0 Volts	0.0 Volts	Minimum output voltage for modulated heating.
Maximum AO Voltage	0.0 to 10.0 Volts	0 Volts	Maximum output voltage for modulated heating. If set to 0 Modulation is disabled

Table 10: DXU-3 Floating Point Valve Heating Settings

Setting	Range	Default	Description
Kp	0.00 to 100.00% per °F	5.00%	Proportional gain of the floating point valve's P+I control loop.
Ki	0.00 to 100.00%	0.05%	Integral gain of the floating point valve's P+I control loop.
Travel Time	0 to 600 seconds	0 seconds	Total time it takes for the floating point heating valve to travel from fully closed to fully open. If set to 0, floating point valve is disabled
Deadband	0.00 to 100.00%	10%	The desired setpoint must be this far or greater from the actual position before modulating the actuator.

Economizer Settings

Displays DXU-3/4 setpoints that specifically relate to economizer operation.

Table 11: DXU-3/4 Economizer Settings

Setting	Range	Default	Description
Economizer Type	Disabled, 2 State Unoccupied On ¹⁾ , 2 State Unoccupied Off ¹⁾ , Modulated Unocc. On, Modulated Unocc. Off,	Disabled	If using an economizer, set this field to a value that describes the type of economizer and whether it should be enabled during unoccupied periods.
Setpoint	40.00 to 70.00 °F (4.44 to 21.11 °C)	55.00 °F (12.78 °C)	Setpoint used for controlling the economizer.
Minimum Fresh Air	0.00 to 100.00%	10.0%	Minimum fresh air position for the modulated economizer.
Kp	0.00 to 100.00% per °F	5.00%	Proportional gain of the economizer's P+I control loop.
Ki	0.00 to 100.00%	0.05%	Integral gain of the economizer's P+I control loop.
Minimum AO Voltage	0.0 to 10.0 Volts	0.0 Volts	Minimum output voltage for the modulated economizer.
Maximum AO Voltage	0.0 to 10.0 Volts	10.0 Volts	Maximum output voltage for the modulated economizer.

Free Cooling Settings

This Parameter structure shows all the settings for Enthalpy. Selecting the individual parameter lets you change its value.

Table 12: DXU-3 Free Cooling

Setting	Range	Default	Description
Type	Return Air Humidity , Global Indoor Humidity, Dry Bulb Temperature	Return Air Humidity	Type of free cooling comparison to perform.
Enthalpy offset	0.0 to 60.0 BTU/lb. (0.0 to 139.6 kjoule/kg)	5.0 BTU/lb. (11.6 kjoule/kg)	Difference between inside enthalpy and outside enthalpy that enables or disables the economizer. ^a
Drybulb offset	0.0 to 20.0 °F (0.0 to 11.1 °C)	5 °F (2.78 °C)	Difference between zone temperature and outside temperature that enables or disables the economizer. ^b

a. This value is only used for "Return Air Humidity Sensor" and "Global Indoor Humidity Sensor" free cooling types.

b. This value is only used for "Dry Bulb Temperature Comparison" free cooling.

Dehumidification Settings

This parameter structure shows all the settings for Dehumidification. Selecting the individual parameter lets you change its value.

Table 13: DXU-3 Dehumidification

Setting	Range	Default	Description
Type	Occupied, Always enabled	Occupied	Type of dehumidification
Setpoint	0.00 to 100.00%	0% (Disabled)	Humidity Setpoint
Shutoff offset	0 to 10 °F (0 to 5.56 °C)	2.0 °	Heating Setpoint offset to shut off dehumidification

Table 14: DXU-3 Floating Point Valve Dehumidification Settings²⁾

Setting	Range	Default	Description
Kp	0.00 to 100.00% per °F	5.00%	Proportional gain of the floating point valve's P+I control loop.
Ki	0.00 to 100.00%	0.05%	Integral gain of the floating point valve's P+I control loop.
Travel Time	0 to 600 seconds	0 seconds	Total time it takes for the floating point dehumidification valve to travel from fully closed to fully open. If set to 0, floating point valve is disabled
Deadband	0.00 to 100.00%	10%	The desired setpoint must be this far or greater from the actual position before modulating the actuator.

Runtimes/Limits

This parameter structure shows all runtime limits for the DXU-3/4. .

Table 15: DXU-3/4 Runtimes/Limits

Setting	Range	Default	Description
Cooling	0 to 65535 hours	1000 hours	Runtime limit for cooling after which a maintenance alarm is generated.
Heating	0 to 65535 hours	1000 hours	Runtime limit for heating after which a maintenance alarm is generated.
Fan	0 to 65535 hours	1000 hours	Runtime limit for fan after which a maintenance alarm is generated.

IAQ Settings

This parameter structure shows the settings for the IAQ Alarm, settings include IAQ Alarm Delay time, Temp Reset Limit and Deadband.

Table 16: IAQ Settings

Setting	Range	Default	Description
IAQ Delay Time	0 - 1000 Min	5min	Time the Alarm will be delayed
Temp Reset Limit	0 - 15 °F	5 °F	Temperature Reset Limit to ensure comfort temperature during IAQ Alarm conditions
Deadband	0-100 ppm	0ppm	Deadband to allow the IAQ to recover from Alarm condition

IAQ Sensor

If the IAQ Mode is set to Analog, this parameter structure needs to be configured.

Table 17: IAQ Sensor Setting

Setting	Range	Default	Description
Min	0-4000 ppm	0 ppm	Minimum ppm Sensor setting
Max	0-4000 ppm	0 ppm	Maximum ppm Sensor setting
Setpoint	0-4000 ppm	0 ppm	Setpoint
Offset	0-4000 ppm	0 ppm	Offset to the Sensor reading

Backup Occ Time/ Backup Unocc Time

The Backup time for Unoccupied and occupied mode is stored in the controller.

Table 18:

Setting	Range	Default	Description
Hours	0-23	0	Hour to start occupancy/unoccupancy
Minutes	0-59	0	Minute to start occupancy/unoccupancy

OAT Cutoff

The OAT cutoff temperatures are temperatures above or below heating or cooling function is disabled and the economizer is reduced to the MinAir position.

Table 19:

Setting	Range	Default	Description
Max OAT Heat	-7.6 to 122 °F (-30 to 50 °C)	-4 °F	Outside Air Temperature above which mechanical heating is disabled
Min OAT Cool	-7.6 to 122 °F (-30 to 50 °C)	-4 °F	Outside Air Temperature below which mechanical cooling is disabled
Max OAT Econ	-7.6 to 122 °F (-30 to 50 °C)	-4 °F	Outside Air Temperature above which economizer is in Min Air position
Min OAT Econ	-7.6 to 122 °F (-30 to 50 °C)	-4 °F	Outside Air Temperature below which economizer is in Min Air position

Note: A value of -4 °F disables this cutoff temperature setting. All other values within the range are valid cutoff temperatures.

Inputs

The Inputs screen displays the current values of the DXU-3/4's inputs. These values cannot be changed.

Table 20: DXU-3/4 Inputs

Setting	Range	Description
Outside Air Temperature	-29 to 230 °F (-30 to 50 °C)	The outside air temperature communicated through the LCI.
Inside Enthalpy	0.0 to 60.0 BTU/lb. (0.0 to 139.6 kjoule/kg)	Calculated inside air enthalpy.
Outside Enthalpy	0.0 to 60.0 BTU/lb. (0.0 to 139.6 kjoule/kg)	Calculated outside air enthalpy.
Space Temperature	-29 to 230 °F (-30 to 50 °C)	The space temperature reported by the digital thermostat module.
Occ Ext time Rem	0-1000	Number of minutes remaining in extended occupancy
Smoke Detector	Normal, Smoke	Status of the smoke detector (SMK).
Fan Status	Off, On	Status of the fan proof switch (FNP)
Low Limit	Normal, Low limit	Status of the mixed air low limit indication switch (MLL).
Filter Status	Normal, Dirty	Status of the filter switch (FIL).
Indoor Air Quality	Normal, Alarm	Status of the indoor air quality sensor (IAQ).
Occupancy Mode	Occupied, Unoccupied, Bypass	Occupancy mode of controller
Supply Air Temperature	-29 to 230 °F (-30 to 50 °C)	Temperature reported by the SAT sensor.
Mixed Air Temperature	-29 to 230 °F (-30 to 50 °C)	Temperature reported by the MAT sensor.
Return Air Humidity	0.00 to 100.00%	Humidity reported by the RAH sensor.

Outputs

This screen displays the current values of the DXU-3/4's outputs. These values cannot be changed.

Table 21: DXU-3/4 Outputs

Setting	Range	Description
Mode	Heat, Cool, Off, Fan, Free Cooling, Dehumid, Shut down	Operating mode
Heat Output	0.00% to 100.00%	Current status of the heating outputs..
Cool Output	0.00% to 100.00%	Current status of the cooling outputs.
Economizer Output	0.00% or 100.00%	Current status of the economizer output.
Fan Output	0.00% or 100.00%	Current status of the fan output.
In Alarm	Yes, No	Alarm indication
Dehumid Reheat Pos ²⁾	0.00% to 100.00%	Current Position of the Reheat FP Valve, when in Dehumid Mode
Humidification ²⁾	On, Off	Status of Humidification Output

Troubleshooting

Diagnostic LEDs

The controller has 3 LED indicators. These indicators can aid in troubleshooting equipment operation problems. The following table lists the functions of the controller’s LEDs in the order they appear from top to bottom on the unit.

Table 22: Controller LED Indicators.

LED	Indication
Service	– Illuminated when the service pin is pushed
Status	– Solid green when running and configured by an LCI – Flashing green when running and NOT configured by an LCI – Solid red when a fault condition exists – Blinking Red - the controller has a device failure – Solid Amber - The controller has not received a LCI ping message in over 10 mins
Network	– Yellow while the controller is transmitting data onto the FTT-10A network – Green when there is network activity – Off when there is no network activity

Figure 12: DXU-3/4 Controller LEDs

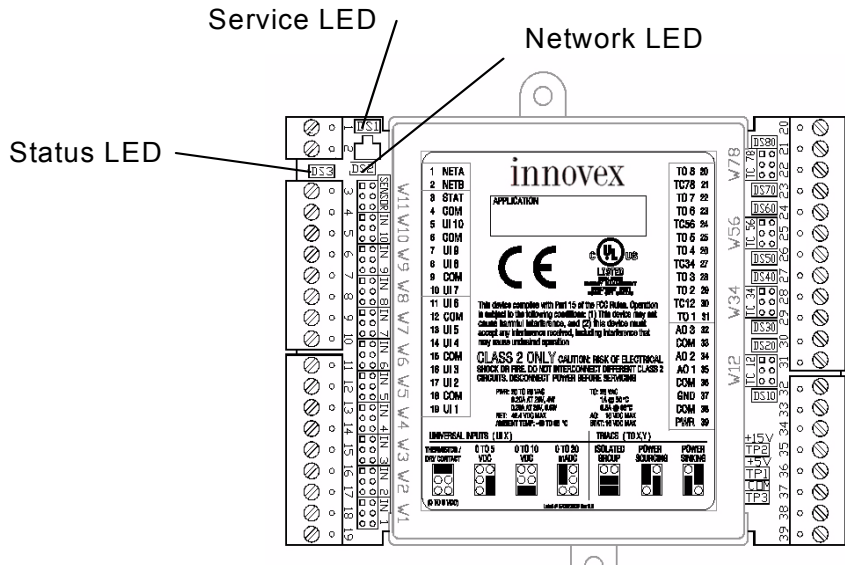

Troubleshooting Tips

Controller is not running and Status LED is not illuminated.

No power to controller. Verify the voltage on the controller’s power connector (24 VAC).

Fan cycles on for 30 seconds and then turns off.

The controller requires the fan status input to be shorted, normally closed, for proper operation. Ensure that your air flow sensor is working and properly wired to the controller. If you are not using an air flow sensor you must place a jumper between the fan status input and the adjacent common terminal.

The fan will not cycle on after the input has been jumpered or the air flow sensor connected.

If the fan was previously in a fan fault condition, the controller must be reset before proper operation can be restored.

How do I reset the controller?

The controller can be reset by the LCI, or you can cycle power to the controller. Refer to the LCI documentation for more information on resetting the controller using the LCI.

The fan will not cycle on.

There are several reasons the fan may not cycle on, and all should be checked.

1. Are all digital inputs on the controller (except for the fan status input) normally open and wired accordingly?
2. Is the controller in an occupied mode?
3. Has the controller been overridden by the LCI?
4. Is the smoke detector or mixed air low limit indicator (freeze stat) tripped? If so, correct the problem and the controller will automatically start; no reset is necessary.
5. Is the thermostat connected?

The fan and heat/cool pilot relays will not come on even though the LCI indicates it is on.

Ensure that the controller and output pilot relay have been powered with 24 VAC and the output has been correctly wired to the coil of the pilot relay. Also ensure that the pilot relay has a 24 VAC coil.

The 10K thermistor reading is at its maximum or minimum.

The input is either shorted or open.

The economizer damper fails to open.

1. Was the LCI used to select an economizer type other than 'None'?
2. Is the difference between indoor and outdoor enthalpy greater than the economizer setpoint?
3. If "global humidity" is selected, make sure that the ASM is reading a valid humidity and providing it to the network.
4. Is the OAT above or below the economizer lockout (also cutoff)?

The Heat or Cool outputs will not come on even though the space requires conditioned air.

1. Is the OAT above the Max OAT Heat setting (lockout) or below the Min OAT Cool setting?

There is an IAQ alarm but the economizer damper is not at 100%.

1. The space temperature is most likely above or below the space temp +/- IAQ Temp Reset.

The humidifier is not coming on.

1. Has the humidity low limit been configured?
2. Is the current mode heating? The humidifier will only be enabled in the heating mode.

Dehumidification is not being enabled.

1. Dehumidification will not be enabled during the heating mode.
2. Is the controller occupied and is the Space Temperature above the setpoint minus the shutoff offset. Dehumidification will operate during unoccupied mode if the type is configured as always enabled.

