

### FCU-1

The FCU-1 fan coil unit controller is a stand-alone microprocessor based controller for two-pipe fan coil units with a single coil for heating and cooling. This application includes fan coil units with a single modulated analog valve and a fan.

### Overview

A digital input is provided to monitor equipment status. A two wire serial interface is provided for the thermostat. The valve is controlled with an analog output. The unit supply fan is controlled by a triac output.

The controller is based on LONWORKS® networking technology. The controller can be networked to a higher-level control system for monitoring and control applications.

### Features

- Modulated analog valve for heating and/or cooling
- Networking of multiple units
- Individual temperature setpoints for occupied/unoccupied heat and cool
- P+I control of the valve
- LonWorks interface to building automation systems and host products
- Equipment status input for additional safety interlocks
- Thermostat with space temperature, setpoint adjust, fan override, occupancy override
- Fan control energized on call for heating or cooling
- Automatic heat/cool changeover
- Remote sensor capabilities
- Automatic configuration with the LCI
- Alarm/Event reporting

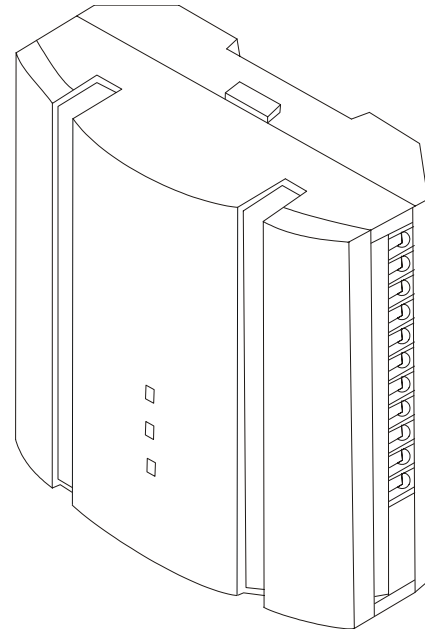

Innovex Technologies  
511 Braddock Avenue  
Turtle Creek, PA 15145  
[www.innovextechnologies.com](http://www.innovextechnologies.com)

iWorX is a trademark of Innovex Technologies  
LON, LONWORKS, & LONMARK are trademarks of Echelon Corporation

## Purpose of This Guide

The *iWorX FCU-1 Application Manual* provides application information for the FCU-1 Controller.

The reader should understand basic HVAC concepts, intelligent environmental control automation, and basic LONWORKS networking and communications. This Application Manual is written for:

- Users who engineer control logic
- Users who set up hardware configuration
- Users who change hardware or control logic
- Technicians and field engineers

## Copyright Notice

This document copyright © 2006, Innovex Technologies. All other intellectual property rights and copyrights related to or arising from these products belong to a third party.

The confidential information contained in this document is provided solely for use by Innovex Technologies employees, licensees, and system owners, and is not to be released to, or reproduced for, anyone else. Neither is it to be used for reproduction of this control system or any of its components.

All specifications are nominal and may change as design improvements occur. Innovex Technologies shall not be liable for damages resulting from misapplication or misuse of its products.

## Applicable Documentation

Part Number	Description	Audience	Purpose
iWorX-FCU-INS-100	iWorX FCU Series Installation Instructions	<ul style="list-style-type: none"> <li>– Application Engineers</li> <li>– Installers</li> <li>– Service Personnel</li> <li>– Start-up Technicians</li> </ul>	Provides instructions for setting up and using the iWorX FCU-1, FCU-2, FCU-3, FCU-4 Controllers.
iWorX-LCI1-USR-100	iWorX LCI User's Guide	<ul style="list-style-type: none"> <li>– Application Engineers</li> <li>– Installers</li> <li>– Service Personnel</li> <li>– Start-up Technicians</li> <li>– End user</li> </ul>	Provides instructions for setting up and using the iWorX Local Control Interface.
iWorX-DTM-INS-100	iWorX DTM Series General Instructions	<ul style="list-style-type: none"> <li>– Application Engineers</li> <li>– Installers</li> <li>– Service Personnel</li> <li>– Start-up Technicians</li> </ul>	Provides step-by-step installation and checkout procedures for iWorX Digital Thermostat Modules. Also contains instructions for sensor operation.
Additional Documentation	<i>LonWorks FTT-10A Free Topology Transceiver User's Guide</i> , published by Echelon Corporation. It provides specifications and user instructions for the FTT-10A Free Topology Transceiver.		

## Application Description

The FCU-1 controller maintains the temperature of a space at defined setpoints. Figure 1 illustrates a typical controller application. The control is achieved by modulating the cooling/heating valve of a single coil two-pipe fan coil unit based on the current space requirements.

**Figure 1: Two-pipe FCU with Analog Valve**

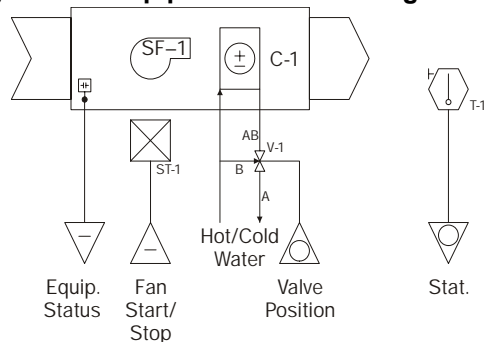

The controller controls the starting and stopping of the supply air fan. The fan will be energized when there is a call for heating or cooling. During the occupied periods, the fan can be configured to run continuously. The fan can be overridden from the local thermostat. If overridden, the fan will run continuously.

The controller can control heating only, cooling only or heating/cooling fan coil units. Automatic seasonal changeover is provided for heating and cooling. A remote pipe mounted temperature sensor is placed on the supply water line. The control is switched when the sensor detects a change in supply temperature between hot and cold water.

When cooling, the valve position is calculated by a Proportional + Integral control loop based on the space temperature and the cooling setpoint. As the temperature increases above the cooling setpoint, the valve will be modulated open. The valve will be modulated closed as the temperature decreases below the cooling setpoint. When unoccupied mode is entered, the cooling setpoint is set up.

When heating, the valve position is calculated by a Proportional + Integral control loop based on the space temperature and the heating setpoint. As the temperature decreases below the heating setpoint, the valve will be modulated open. The valve will be modulated closed as the temperature increases above the heating setpoint. When unoccupied mode is entered, the heating setpoint is set back.

Each controller interfaces to a local thermostat. The thermostat includes a space temperature sensor, temperature setpoint adjustment, occupancy override, and a fan auto/on selection (depending on the model).

The controller operates in one of two states: occupied or unoccupied. The LCI determines the active operating mode. The controller maintains the comfort level to a user-defined setpoint during the occupied period. The controller uses setup and setback values during the unoccupied period to maintain the space temperature. An optional backup schedule is provided for cases when the LCI is not available.

A digital input is provided to monitor the status of the equipment within the unit. An external contact may be wired to the input to provide additional equipment safety interlocks. When the contact closes, the controller shuts the unit down. An alarm will be reported to the LCI when this condition exists.

The controller monitors the runtime of the fan. When the runtime exceeds a programmable limit, a maintenance alarm will be reported to the LCI.

When the space temperature exceeds a programmable limit, a high limit alarm will be reported to the LCI. When the space temperature drops below a programmable limit, a low limit alarm will be reported to the LCI. When the space temperature returns to the proper range, a return to normal alarm will be reported to the LCI.

## Sequence of Operation

This section describes the detailed sequence of operation for the controller control algorithms.

**Figure 2: Valve Control in Heating Mode**

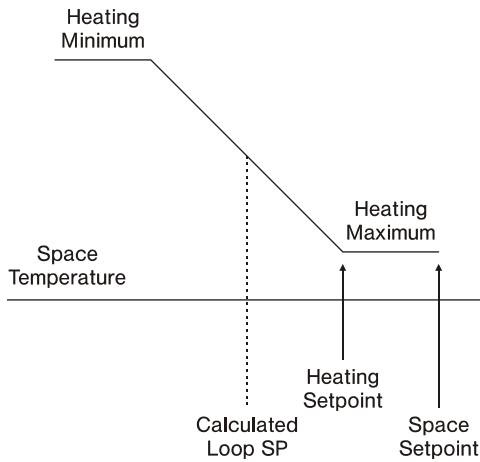

**Figure 3: Valve Control in Cooling Mode.**

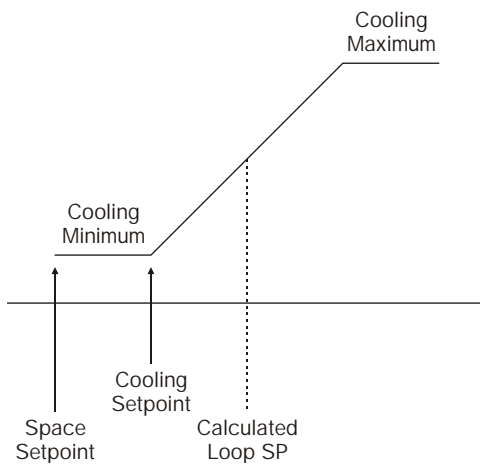

## Setpoints

The heating and cooling setpoint for both occupied and unoccupied periods are programmable values. The space setpoint is a calculated value based on the programmed heating setpoint, cooling setpoint and current operating mode (i.e. occupied or unoccupied).

The space setpoint is derived by first calculating the zero energy band (zeb) for the current operating mode.

### Occupied Mode

$$ZebOcc = OccupiedCoolSp \angle OccupiedHeatSp$$

### Unoccupied Mode

$$ZebUnocc = UnoccupiedCoolSp \angle UnoccupiedHeatSp$$

The space setpoint is calculated from the zero energy band and the heating setpoint.

### Occupied Mode

$$SpaceSP = OccupiedHeatsp + \frac{ZebOcc}{2}$$

## Unoccupied Mode

$$SpaceSp = UnoccupiedHeatSp + \frac{ZebUnocc}{2}$$

**Figure 4: Space Setpoint Calculation**

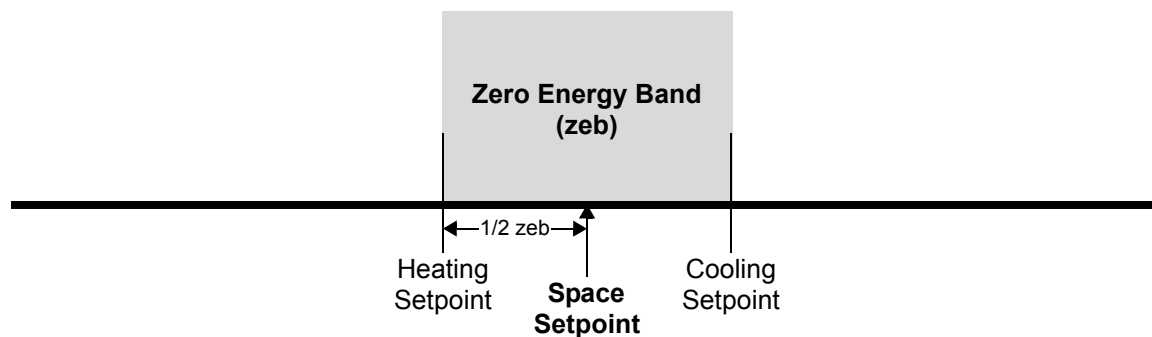

The effective setpoint is a calculated value based on the space setpoint and the thermostat setpoint offset value. The setpoint offset is used to increase or decrease the space setpoint from the local thermostat. The offset value is limited to plus or minus the programmed setpoint adjustment.

The setpoint offset also affects the calculated heating and calculated cooling setpoints by an equal amount. The setpoint offset only applies in the occupied mode of operation. It has no effect in the unoccupied mode. Note that the actual programmed heating and cooling setpoints are not changed. The offset is simply added to the programmed setpoints to derive the calculated values.

## Occupied Mode

$$CalcCoolingSp = OccupiedCoolingSp \pm SpOffset$$

$$CalcHeatingSp = OccupiedHeatingSp \pm SpOffset$$

$$EffectiveSp = SpaceSp \pm SpOffset$$

### Unoccupied Mode

$$CalcCoolingSp = UnoccupiedCoolingSp$$

$$CalcHeatingSp = UnoccupiedHeatingSp$$

$$EffectiveSp = SpaceSp$$

**Figure 5: Setpoint Adjustment**

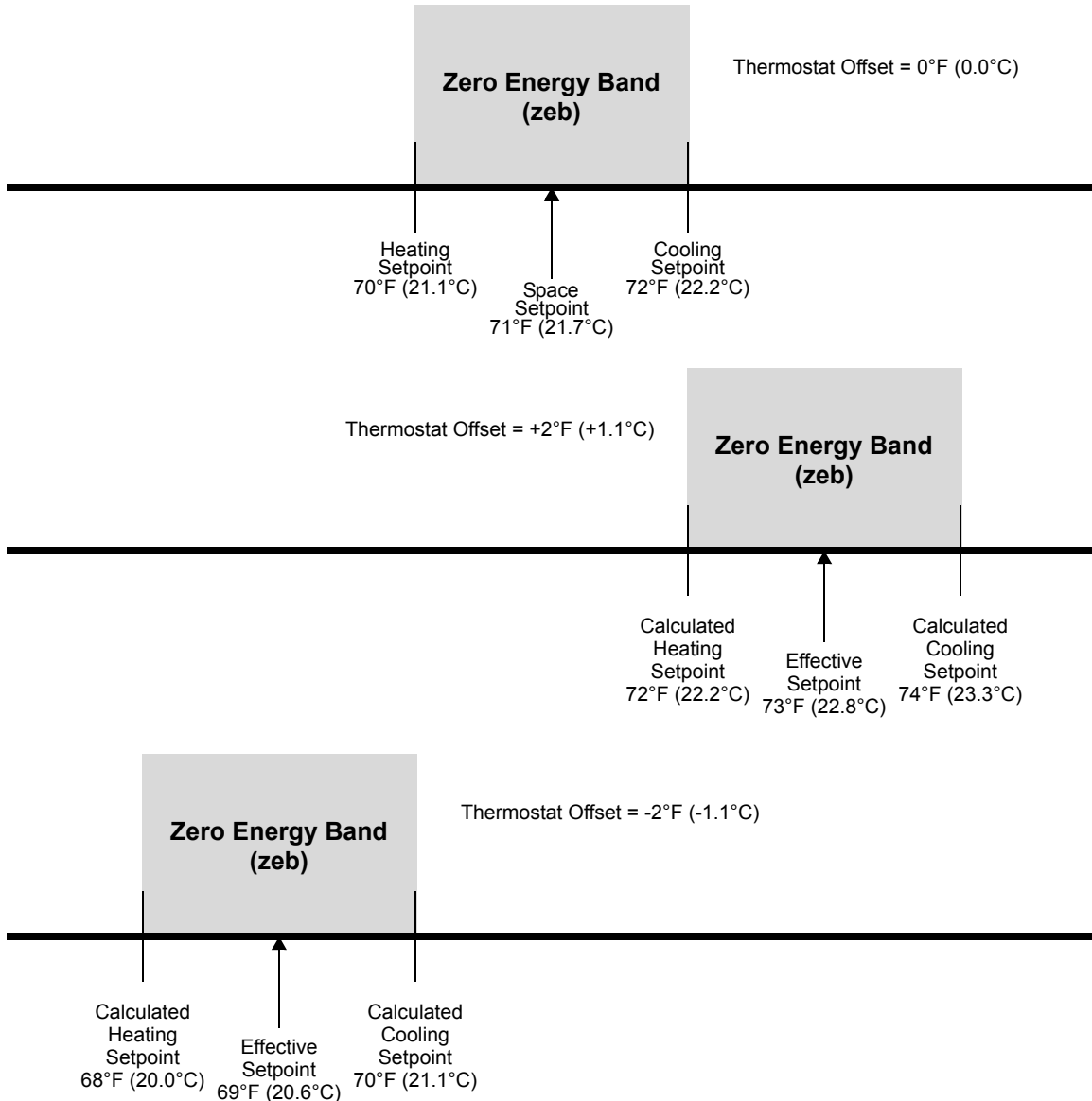

### Heating/Cooling Changeover

The valve can operate in a heating or cooling mode. When set to automatic changeover, the mode of operation is determined by the supply water temperature as measured by an external water temperature sensor. The changeover point can be configured by the user. When the water temperature is above the changeover setpoint the valve will operate in a heating mode. When the water is below the changeover setpoint the valve will operate in the cooling mode.

An optional manual changeover feature is also provided. In this case, the changeover command is received from the LCI.

## Heating Control

The calculated heating loop setpoint is derived from the heating setpoint and the loop proportional gain.

$$\text{CalcHeatingLoopSp} = \text{CalcHeatingSp} \angle \frac{1}{2(K_p)}$$

The heating valve is modulated by a Proportional + Integral (P+I) control loop based on the heating loop setpoint and the space temperature. The P+I control loop will modulate the valve to maintain a constant space temperature. As the temperature decreases below the heating loop setpoint, the heating valve will be modulated open. The heating valve will be modulated closed as the temperature increases above the heating loop setpoint. When unoccupied mode is entered, the heating loop setpoint is set back through a separate unoccupied heating setpoint.

To prevent the integral component from becoming too large, there is anti-wind up reset protection. This protection clamps the integral value when all of the components add up to more than 100% or less than 0%. The following equations are used for P+I control:

$$K_p = \text{Proportional Gain}$$

$$K_i = \text{Integral Gain}$$

$$\text{Error} = \text{HeatingLoopSp} \angle \text{SpaceTemp}$$

$$I = I + (K_i \times \text{Error})$$

$$\text{HeatPosition} = (K_p \times (\text{Error} + I)) + 50.00\%$$

## Cooling Sequence

The calculated cooling loop setpoint is derived from the calculated cooling setpoint and the loop proportional gain.

$$\text{CalcCoolingLoopSp} = \text{CalcCoolingSp} + \frac{1}{2(K_p)}$$

The cooling valve is modulated by a Proportional + Integral (P+I) control loop based on the cooling loop setpoint and space temperature. The P+I control loop will modulate the valve to maintain a constant space temperature. As the temperature increases above the cooling loop setpoint, the cooling valve will be modulated open. The cooling valve will be modulated closed as the temperature decreases below the cooling loop setpoint. When unoccupied mode is entered, the cooling setpoint is set up through a separate unoccupied cooling setpoint.

To prevent the integral component from becoming too large, there is anti-wind up reset protection. This protection clamps the integral value when all of the components add up to more than 100% or less than 0%. The following equations are used for P+I control:

$$K_p = \text{Proportional Gain}$$

$$K_i = \text{Integral Gain}$$

$$\text{Error} = \text{SpaceTemp} \angle \text{CoolingLoopSp}$$

$$I = I + (K_i \times \text{Error})$$

$$\text{CoolPosition} = (K_p \times (\text{Error} + I)) + 50.00\%$$

## Fan Operation

During occupied periods, you can set the fan to always run or to cycle off when the space temperature is within the zero energy band. The zero energy band is defined as the temperature range between the cooling and heating setpoints. The fan is interlocked with the cooling and heating stages. If there is a call for heating or cooling, the fan will immediately energize. During the unoccupied period, the fan will always cycle off when the space temperature is within the zero energy band.

You can override the fan from the local thermostat (depending on the model). When the fan selection is set to *Auto*, the fan operates as described above. If the fan selection is set to *On*, the fan will be constantly on.

## Equipment Status

An equipment status input is monitored to determine if the fan coil equipment is operating properly. When the fan is initially turned on, there is a 30 second delay before the equipment status input is checked. If the contact closes after the delay, indicating equipment failure, the valve will close and the fan will turn off. To clear this condition, reset the controller.



**NOTE:** The status LED on the controller will turn solid red if the equipment fails.

## Thermostat

The space temperature value, setpoint adjustment, fan auto/on status (depending on the thermostat model), and occupancy override request are monitored by the thermostat and sent to the controller.

The controller will automatically detect a failure of the thermostat. When the thermostat fails, the valve will close, the fan will turn off, and control will be disabled.



**NOTE:** The thermostat must be connected. The status LED on the controller will turn solid red if the thermostat is not connected. Once the thermostat is connected, the status LED will turn green indicating normal operation.

## Local Backup Schedule

The LCI normally determines the operating mode. You can define a local backup schedule for situations when the LCI is not available. When the controller detects that the LCI is not available (after 10 minutes without communication), it resorts to the local backup schedule that you have configured. If the local backup schedule is disabled, the controller defaults to occupied mode.

You configure the *occupied* and *unoccupied* times that are used in determining the current operating mode of the controller when it is running the backup schedule. By default, both the unoccupied and occupied time will be set to zero, which disables the local backup schedule. This causes the controller to default to the occupied mode of operation if it cannot communicate with the LCI.

## Runtime Accumulation

The total runtime is accumulated for the fan output. The runtime can be used to indicate that maintenance is required on the fan. The runtime can be reset by an operator or maintenance person once servicing has been performed.

## Alarms and Events

The controller will detect certain alarm conditions and send them to the LCI. Before this can occur, you must use the LCI to configure the controller.

### Digital Input Alarm

The controller monitors the status of the equipment status digital input and generates an Equipment Status Alarm if detected.

## Thermostat Failure

The controller automatically detects the presence of the local thermostat and monitors its status. If the thermostat fails to communicate with the controller, a Thermostat Failed Alarm will be generated and the controller's status LED will turn red.

## Maintenance Alarm

The controller provides a single programmable run limit for generating a runtime Maintenance Alarm. When the fan runtime exceeds this limit, a Maintenance Alarm is sent to the LCI.

## Space Temperature Alarms

The controller generates high and low limit alarms for the space temperature. You can configure a programmable space temperature alarm limit offset. The temperature limits are calculated based on the control setpoints, alarm limit offset, and control band.

$$HighLimit = CalcCoolingSp + AlarmLimitOffset + CoolBand$$

$$LowLimit = CalcHeatingSp \angle AlarmLimitOffset \angle HeatBand$$

When the measured space temperature exceeds the high limit, a high limit alarm (Space Temperature High Limit Alarm) is generated. When the space temperature drops below the low limit, a low limit alarm is generated (Space Temperature Low Limit Alarm). A return to normal alarm is generated when the space temperature is between the high and low limit (Space Temperature Return to Normal).

When the controller switches between the unoccupied and occupied modes of operation, no space temperature alarms are reported for 30 minutes following the switch. This helps eliminate nuisance alarms.

## Controller Identification

You need to press the controller's service pin to allow the LCI to identify it. The controller's status light will be flashing green until it is configured, and will be solid green after it is configured. The controller must be configured by the LCI to allow you to use the LCI to set the controller's schedules, change its setpoints, etc. You need to press the service pin after the controller is installed and the LCI is active on the network.

# Troubleshooting

## Diagnostic LEDs

The controller has 3 LED indicators. These indicators can aid in troubleshooting equipment operation problems. The following table lists the functions of the controller's LEDs in the order they appear from top to bottom on the unit.

**Table 1: Controller LED Indicators.**

LED	Indication
Service	– Illuminated when the service pin is pushed
Status	– Solid green when running and configured by an LCI – Flashing green when running and NOT configured by an LCI – Solid red when a fault condition exists
Network	– Yellow while the controller is transmitting data onto the FTT-10A network – Green when there is network activity – Off when there is no network activity

**Figure 6: FCU-1 Controller LEDs.**

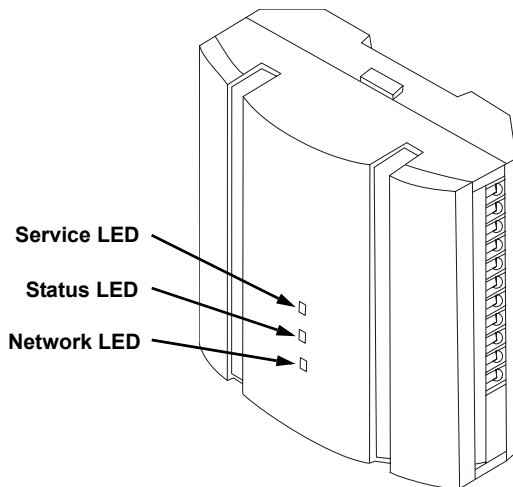

## Troubleshooting Tips

### **Controller is not running and Status LED is not illuminated**

No power to controller. Verify the voltage on the controller's power connector (24 VAC).

### **The fan will not cycle on**

There are several reasons the fan may not cycle on and all should be checked.

1. Is the controller in an occupied mode?
2. Has the controller been overridden by the LCI?
3. Is the thermostat connected?
4. Does the unit have no alarms, and is the Status LED solid green?

### **How do I reset the controller?**

The controller can be reset by the LCI, or you can cycle power to the controller. Refer to the LCI documentation for more information on resetting the controller using the LCI.

### **The fan relay will not come on, though the LCI indicates it is on**

Ensure that the controller has been powered with 24 VAC and the output has been correctly wired to the coil of the pilot relay. Also ensure that the pilot relay has a 24 VAC coil.

## Network Variables and Configuration Variables

This section describes all of the Network and Configuration Variables used in the controller.

**Table 2: FCU-1 Inputs.**

LCI Variable Name	Range	Default Value	Description
Space Temperature	-22 °F to 122 °F (-30 °C to 50 °C), or Auto	Auto	Network override of the actual space temperature provided by the local thermostat
Temp Setpoint	50 °F to 95 °F (10 °C to 35 °C), or Auto	Auto	Network override for effective setpoint (when not in Auto, value overrides thermostat)
Occupancy Cmd	Occ, Unocc, Bypass, Auto	Auto	Network override for occupancy command
Reset Runtimes	Off, On	Off	Resets the runtime hours for heating, cooling and fan (can be set through LCI interface)
System Time	00:00 to 23:59	00:00	System clock value (not used by LCI)
Water Temp	32 °F to 194 °F (0 °C to 90 °C)	Not Avail	External supply water temperature
Application Mode	Auto, Heat, Cool, Off, Fan	Auto	Network variable is used to command the controller into different operating modes

The following output variables are read only and cannot be changed.

**Table 3: FCU-1 Outputs.**

LCI Variable Name	Range	Description
Space Temperature	-22 °F to 122 °F (-30 °C to 50 °C), or Auto	Measured space temperature
Mode	Auto, Heat, Cool, Off, Fan	Operating mode
Heat Output	0 to 100%	Capacity of heating used
Cool Output	0 to 100%	Capacity of cooling used
Fan Output	0 to 100%	Off=0, ON=100%
In Alarm?	No, Yes	Alarm indication
Effective Setpt	50 °F to 95 °F (10 °C to 35 °C)	Effective temperature setpoint
Occ. Ext. Time Rem.	0 to 1000 minutes	Occupancy override time remaining
Equipment Status	Normal, Failed	Current state of the equipment status input
Occupancy Mode	Occ, Unocc, Bypass, Auto	Current occupancy mode
Fan Runtime	0 to 65,535 hours	Runtime hours for the fan

**Table 4: FCU-1 Setpoints.**

<b>LCI Variable Name</b>	<b>Range</b>	<b>Default Value</b>	<b>Description</b>
Occupied Cool	50 °F to 95 °F (10 °C to 35 °C)	72°F (22.2 °C)	Occupied cooling setpoint
Unoccupied Cool	50 °F to 95 °F (10 °C to 35 °C)	82°F (27.8 °C)	Unoccupied cooling setpoint
Occupied Heat	50 °F to 95 °F (10 °C to 35 °C)	70°F (21.1 °C)	Occupied heating setpoint
Unoccupied Heat	50 °F to 95 °F (10 °C to 35 °C)	60°F (15.6 °C)	Unoccupied heating setpoint
Space Temp Limit	0 °F to 15 °F (0 °C to 8.3 °C)	5 °F (2.8 °C)	Space temperature limit offset for alarming purposes
Valve Prop. Gain	0.00 to 100.00% per °F	50.00%	Proportional gain of the valve P+I control loop
Valve Integ. Gain	0.00 to 100.00%	0.10%	Integral gain of the valve P+I control loop
Valve Min Output	0.0 to 10.0 volts	0.0 volts	Minimum output value of the modulated valve output
Valve Max Output	0.0 to 10.0 volts	10.0 volts	Maximum output value of the modulated valve output
Changeover Setpt	32 °F to 194 °F (0 °C to 90 °C)	120 °F (48.9 °C)	Heat/cool changeover setpoint
Fan Type	Auto, On	Auto	Type of fan operation
Setpoint Adjust	0 °F to 10 °F (0 °C to 5.6 °C)	5 °F (2.8 °C)	Allowed range of the setpoint adjustment
Occ. Extend Time	0 to 1000 minutes	60 minutes	Allowable occupancy extension time
Fan Runtime Limit	0 to 65,535 hours	1000 hours	Runtime limit for fan
Occupied Time	00:00 to 23:59	00:00	Occupied time for local backup schedule (if both Occupied Time and Unoccupied Time are zero, the local backup schedule is disabled)
Unoccupied Time	00:00 to 23:59	00:00	Unoccupied time for local backup schedule