



# iWorX HPU Series Installation Instructions

## HPU-1

The iWorX HPU-1 is a self-contained interoperable controller for liquid source heat pump units. You can use the HPU-1 to control liquid source heat pump units with two-stage compressor, reversing valve, and fan. Individual occupied and unoccupied temperature setpoints are provided for both heating and cooling cycles.

## Application

HPU Series controllers support a digital thermostat module. Basic to each unit is a removable electronics module with LED indicators. Coupled to this module is a DIN rail or panel-mount base module with field wiring terminal blocks.

Controllers function in standalone mode, or as part of a LONWORKS® network using the integral FTT-10 Free Topology communications transceiver. This network interface enables the controllers to be integrated with a building automation system. For safety interlocking, HPU Series controllers also have an equipment status input.

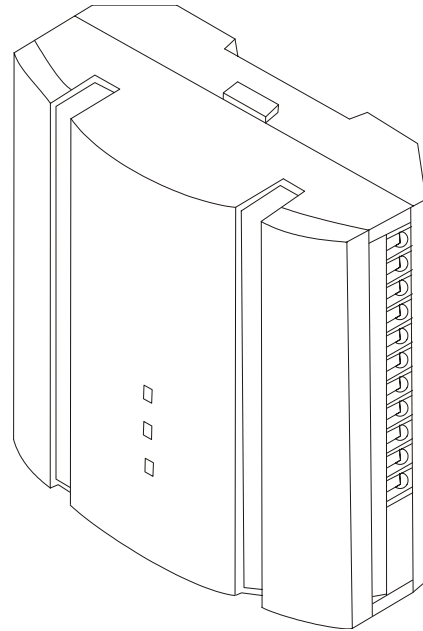

## Applicable Documentation

| Description                    | Audience   | Purpose  |
|--------------------------------|--|--|
| iWorX LCI User's Guide         | <ul style="list-style-type: none"> <li>– Application Engineers</li> <li>– Installers</li> <li>– Service Personnel</li> <li>– Start-up Technicians</li> <li>– End user</li> </ul>               | Provides instructions for setting up and using the iWorX Local Control Interface.                                |
| iWorX HPU-1 Application Manual | <ul style="list-style-type: none"> <li>– Application Engineers</li> <li>– Wholesalers</li> <li>– Contractors</li> </ul>  | Provides specific application information about the HPU-1, including sequence of operation and SNVT information. |
| Additional Documentation       | <i>LonWorks FTT-10A Free Topology Transceiver User's Guide</i> , published by Echelon Corporation. It provides specifications and user instructions for the FTT-10A Free Topology Transceiver. |  |

## Typical Use

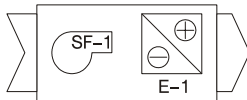

Innovex Technologies  
511 Braddock Avenue  
Turtle Creek, PA 15145  
[www.innovextechnologies.com](http://www.innovextechnologies.com)

iWorX is a trademark of Innovex Technologies  
LON, LONWORKS, & LONMARK are trademarks of Echelon Corporation

## Precautions

### General



This symbol is intended to alert the user to the presence of important installation and maintenance (servicing) instructions in the literature accompanying the equipment.



**Warning:** Electrical shock hazard. Disconnect **ALL** power sources when installing or servicing this equipment to prevent electrical shock or equipment damage.

Make all wiring connections in accordance with these instructions and in accordance with pertinent national and local electrical codes. Use only copper conductors that are suitable for 167 °F (75 °C).

### Static Electricity

Static charges produce voltages that can damage this equipment. Follow these static electricity precautions when handling this equipment.

- Work in a static free area.
- Touch a known, securely grounded object to discharge any static charge you may have accumulated.
- Use a wrist strap when handling printed circuit boards. The wrist strap must be secured to earth ground.

### Location

Avoid locations where corrosive fumes, excessive moisture, vibration or explosive vapors are present.

Avoid electrical noise interference. Do not install near large contactors, electrical machinery, or welding equipment.

This equipment is intended for indoor use only. Preferably, or as required by National Electrical Code, the unit is intended to be installed within an electrical control enclosure. Operate where ambient temperatures do not exceed 122 °F (50 °C) or fall below 32 °F (0 °C) and relative humidity does not exceed 90%, non-condensing.

### For Installation in the United States

This equipment has been tested and found to comply with the limits for a Class A digital device, pursuant to Part 15 of the FCC rules. These limits are designed to provide reasonable protection against harmful interference. This equipment can radiate radio frequency energy and, if not installed and used in accordance with the instructions, may cause harmful interference to radio communications. However, there is no guarantee that interference will not occur in a particular installation. If this equipment does cause harmful interference to radio or television reception, which can be determined by turning the equipment off and on, the user is encouraged to try to correct the interference by one or more of the following measures:

- Reorient or relocate the receiving antenna.
- Increase the separation between the equipment and the receiver.
- Connect the equipment to a power source different from that to which the receiver is connected.
- Consult the equipment supplier or an experienced radio/TV technician for help.

You are cautioned that any changes or modifications to this equipment not expressly approved in these instructions could void your authority to operate this equipment.

### For Installation in the European Community

This equipment meets the requirements of the European Community Directives for Electromagnetic Compatibility (EMC Directive 89/336/EE).

## Before Installing

### About this Document

The instructions in this manual are for the HPU-1 module which supports a liquid source heat pump.

### Inspecting the Equipment

Inspect the shipping carton for damage. If damaged, notify the carrier immediately. Inspect the equipment for damage. Return damaged equipment to the supplier.

### What is Not Included with this Equipment

- A power source for the equipment electronics and peripheral devices.
- Tools necessary to install, troubleshoot and service the equipment.
- The screws or DIN rail needed to mount the device.
- Peripheral devices, such as sensors, actuators, etc.
- Cabling, cabling raceway, and fittings necessary to connect this equipment to the power source, FTT-10A network and peripheral devices.

### Equipment Location



Abide by all warnings regarding equipment location provided earlier in this document.

Optimally, the equipment should be installed within a secure enclosure.

The equipment must be installed indoors unless contained within a protective enclosure. The enclosure must maintain internal temperature and humidity within the ranges specified for this equipment.

The equipment must be installed within 500 feet of all input peripherals (smoke detectors, sensors, etc.) that will be connected to the equipment. It must be within 200 feet of any connected thermostats.

### Selecting a Power Source

This equipment requires a UL recognized or CE marked (as appropriate) external power source (not supplied) to operate. The controller power input requires a voltage of 24 volts AC.

To calculate power source current requirements, add the power consumption of all peripheral devices to that of the controller.

The controller and triac output loads can use the same power source. The loads must have EMF protection. This protection can be integral to the load, or installed across the load's coil.

To provide necessary RFI and transient protection, the controller's ground (GND) pin (T28) must be connected to earth ground or the earth ground of the packaged unit's enclosure ground. Failure to properly ground the controller may cause it to exceed FCC & CE limits. Excessive noise could also produce inaccurate sensor data. The power source must be capable of operating with this connection to ground.

### Installation



**Warning:** Electrical shock hazard. To prevent electrical shock or equipment damage, disconnect **ALL** power sources to controllers and loads before installing or servicing this equipment or modifying any wiring.

### Mounting the Device

1. Select mounting location. Enclosure mounting is recommended.
2. Do one of the following:
  - a. Using two #6 pan head screws, mount base of controller to a panel.

- b. Snap controller base on a 35 mm DIN mounting rail (not provided).
- 3. Wire controller base (See Routing Cabling to the Device).
- 4. After wiring:
  - a. Line up terminal pins with the correct sockets on the terminal blocks.
  - b. Insert cover tabs into brackets on the base of the controller.
  - c. Push gently until the cover snaps into place.

**Figure 1: Mounting Dimensions.**

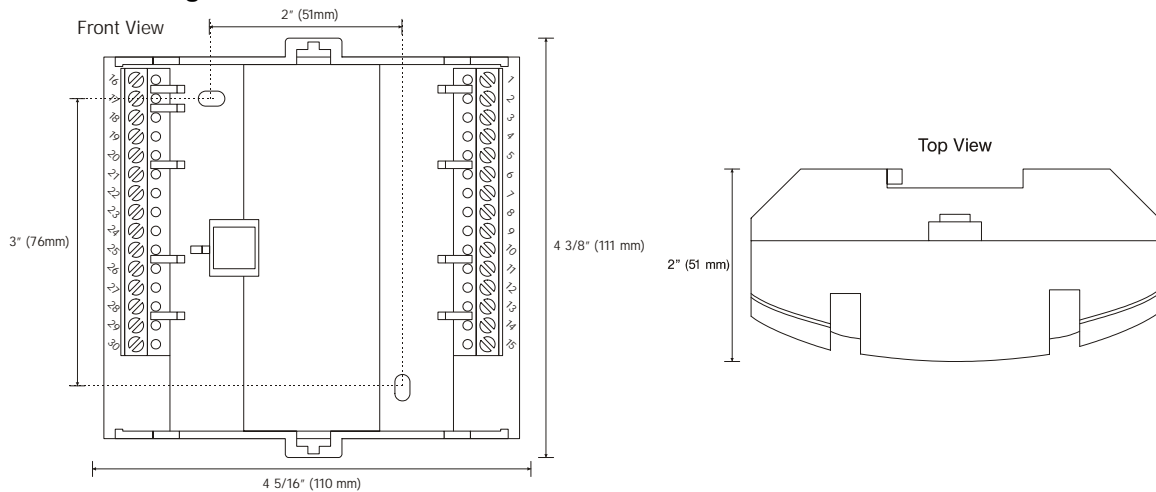

## Routing Cabling to the Device



Cabling used to connect the power source and cabling used to connect the FTT-10A network must remain separated within the control enclosure and wiring conduit.

## Grounding the Device



The ground terminal (T28) must be securely connected to earth ground. Failure to properly ground this equipment may increase the risk of electrical shock and may increase the possibility of interference to radio/TV reception.



Connecting the device commons (COM) to earth ground will also connect the power source to earth ground.

## Wiring Information



**WARNING:** Terminals 2 and 26 are connected internally on all HPU Series controllers. Disconnect **ALL** power sources when installing or servicing this equipment to prevent electrical shock or equipment damage.

**Figure 2: HPU-1 Terminal Connections**

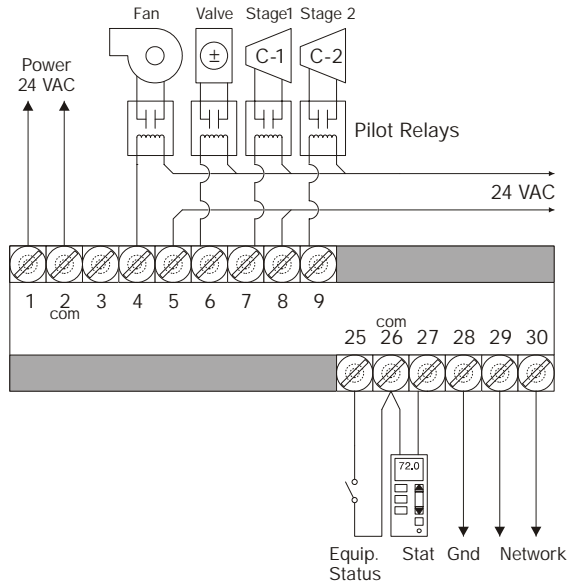

## Connecting Input Devices

### Equipment Status (EQS)

To connect the equipment status contact to the unit, connect one wire from the contact to EQS (T25) and the other wire to the adjacent COM (T26).

### STAT (S-LK)

Connect one wire of an Innovex Technologies Stat device to the S-LK (T27) terminal. Connect the other wire to COM (T26).

## Connecting Output Devices

### Compressor Outputs (S1, S2)

The stage 1 and stage 2 compressor outputs must be connected to 24 VAC pilot relays. See Figure 2 on page 5 for details.

### Reversing Valve Output (RV)

The reversing valve must be connected to a 24 VAC pilot relay. See Figure 2 on page 5 for details.

### Fan (FAN)

The fan output must be connected to a 24 VAC pilot relay. See Figure 2 on page 5 for details.

## Other Connections

### Network (LON)

Network wiring must be twisted pair. One network wire must be connected to one LON (T29) terminal and the other network wire must be connected to the other LON (T30) terminal. Polarity is not an issue since an FTT-10A network is used for communications.

### Power (PWR)

Connect one output wire from a 24 VAC power supply to PWR (T1) and the other output wire from the power supply to the adjacent common terminal (T2).

## Ground (GND, COM1)



Terminals COM1 (T2) and GND (T28) must be connected to earth ground. Failure to properly ground this equipment will result in improper operation. Improper grounding may also increase the risk of electrical shock, and may increase the possibility of interference with radio and TV reception.

# Specifications

## Electrical

### Inputs

- Cabling: twisted shielded pair, 18 AWG recommended—500 feet max. (152 meters)

### Equipment Status

- Dry Contact
- Normally Open

### Thermostat Network

- 12 Volt nominal, internally limited to 0.04 A

### Outputs

#### Stage 1, Stage 2, Reversing Valve, and Fan

- 24 Volts AC
- 1 A rms

### FTT-10A Network

- Speed: 78KBPS
- Cabling: Maximum node-to-node distance: 1312 feet (400 meters)
- Maximum total distance: 1640 feet (500 meters)

**Table 1: Network Wire Specifications**

| Cable Type             | Pairs | Details                              | Connect Air Catalog No. |
|------------------------|-------|--------------------------------------|-------------------------|
| Level 4 22AWG (0.65mm) | 1     | Unshielded, Plenum, U.L. Type CMP    | W221P-2001              |
| Level 4 22AWG (0.65mm) | 1     | Unshielded, Non-Plenum, U.L. Type CM | W221P-1002              |

For detailed specifications, refer to the FTT-10A Free-Topology Transceiver User's Guide published by Echelon Corporation. For information on ordering Connect Air items, contact Connect Air International; 4240 B Street; Auburn, WA 98001 <[www.connect-air.com](http://www.connect-air.com)>.

## Power

### Power Requirements

- 24VAC power (requires an external supply)

### Power Consumption

- With no external loads: 15 VA

## **Mechanical**

### **Housing**

- Dimensions: 4 3/8" high, 4 5/16" wide, 2" deep (111 mm high, 110 mm wide, 51 mm deep)
- ABS Polycarbonate

### **Electronics**

- Processor: 3150 Neuron 10 MHz
- Flash: 48 Kilobytes
- SRAM: 8 Kilobytes
- Termination: 0.197" (5.0 mm) Pluggable Terminal Blocks, 14-22 AWG

### **Environmental**

- Temperature: 32 to 122 °F (0 to 50 °C)
- Humidity: 0 to 95%, non-condensing

### **Agency Listings**

- UL916

### **Agency Compliances**

- FCC Part 15 Class A
- CE

# Troubleshooting

## Diagnostic LEDs

The controllers have 3 LED indicators. These indicators can aid in troubleshooting equipment operation problems. The following table lists the function of each LED in the order it appears from top to bottom on the unit.

**Figure 3: Diagnostic LEDs**

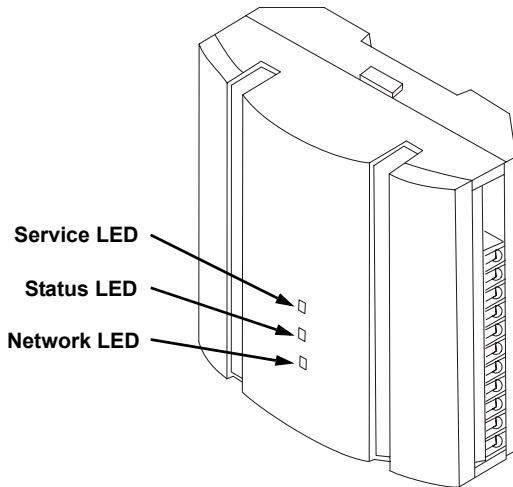

**Table 2: Diagnostic LEDs**

| LED     | Indication   |
|---------|--|
| Service | Illuminated when the service pin is pushed   |
| Status  | Solid green when running and configured by an LCI<br>Flashing green when running and NOT configured by an LCI<br>Solid red when a fault condition exists   |
| Network | Yellow while the controller is transmitting data onto the FTT-10A network<br>Green when there is network activity<br>Off when there is no network activity |

## Troubleshooting Tips

### **Controller is not running and Status LED is not illuminated.**

No power to controller. Verify the voltage on the controller’s power connector (24 VAC).

### **How do I reset the controller?**

The controller can be reset by the LCI, or you can cycle power to the controller. Refer to the LCI documentation for more information on resetting the controller using the LCI.

### **The fan will not cycle on.**

There are several reasons the fan may not cycle on and all should be checked.

1. Is the controller in an occupied mode?
2. Has the controller been overridden by the LCI?
3. Is the thermostat connected?
4. Does the unit have no alarms, and is the Status LED solid green?

### **The fan and valve pilot relays will not come on.**

1. Ensure that the controller has been powered with 24 VAC and the output has been correctly wired to the coils of the pilot relays. Also ensure that the pilot relays have a 24 VAC coil.
2. Ensure that the global unit enable indicates that there is water flow in the main plant.