

LCU-1

The LCU-1 is a self-contained device for controlling facility lighting. The unit can control up to eight lighting zones, and supports up to eight switches that enable occupants to override system control of the lighting. The LCU-1 also supports a photosensor for control of exterior lighting.

Overview

The LCU-1 controls each lighting circuit through digital outputs in the form of triacs. Digital inputs from dry contact switches can override automatic control of lighting zones.

The LCU-1 provides a digital input for photosensor input.

Features

- Configurable lighting zones
- On/Off control of lighting circuit contactors
- Controls up to 24 individual 20 Amp circuits through 8 contactors.
- Multiple units can be networked together
- Scheduled on and off times
- LONWORKS interface to building automation systems
- Occupancy override switches for individual zones
- Automatic configuration through the LCI
- Photosensor operation (one per system)

Purpose of This Guide

The *iWorX LCU-1 Application Manual* provides application information for the Lighting Control Unit.

The reader should understand basic lighting control concepts, intelligent environmental control automation, and basic LONWORKS networking and communications. This Application Manual is written for:

- Users who engineer control logic
- Users who set up hardware configuration
- Users who change hardware or control logic
- Technicians and field engineers

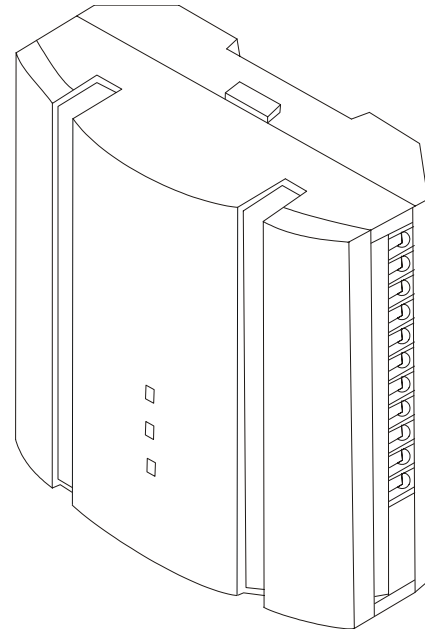

Innovex Technologies
511 Braddock Avenue
Turtle Creek, PA 15145
www.innovextechnologies.com

iWorX is a trademark of Innovex Technologies
LON, LONWORKS, & LONMARK are trademarks of Echelon Corporation

Copyright Notice

This document copyright © 2006, Innovex Technologies. All other intellectual property rights and copyrights related to or arising from these products belong to a third party.

The confidential information contained in this document is provided solely for use by Innovex Technologies employees, licensees, and system owners, and is not to be released to, or reproduced for, anyone else. Neither is it to be used for reproduction of this control system or any of its components.

All specifications are nominal and may change as design improvements occur. Innovex Technologies shall not be liable for damages resulting from misapplication or misuse of its products.

Applicable Documentation

Part Number	Description	Audience	Purpose
iWorX-LCU-INS-100	iWorX LCU Series Installation Instructions	<ul style="list-style-type: none"> – Application Engineers – Installers – Service Personnel – Start-up Technicians 	Provides instructions for setting up and using the iWorX Lighting Control Unit Controller.
iWorX-LC11-USR-100	iWorX LCI User's Guide	<ul style="list-style-type: none"> – Application Engineers – Installers – Service Personnel – Start-up Technicians – End user 	Provides instructions for setting up and using the iWorX Local Control Interface.
Additional Documentation	<i>LonWorks FTT-10A Free Topology Transceiver User's Guide</i> , published by Echelon Corporation. It provides specifications and user instructions for the FTT-10A Free Topology Transceiver.		

Application Description

The LCU-1 controls the state of 24 individual lighting circuits based on the current occupancy mode of the zones and override switch activity. The 24 circuits are handled by eight contactors. The control is achieved by switching individual lighting contactors, each controlling 3-branch circuits. Figure 1 illustrates a typical LCU-1 application.

Figure 1: Typical LCU-1 application

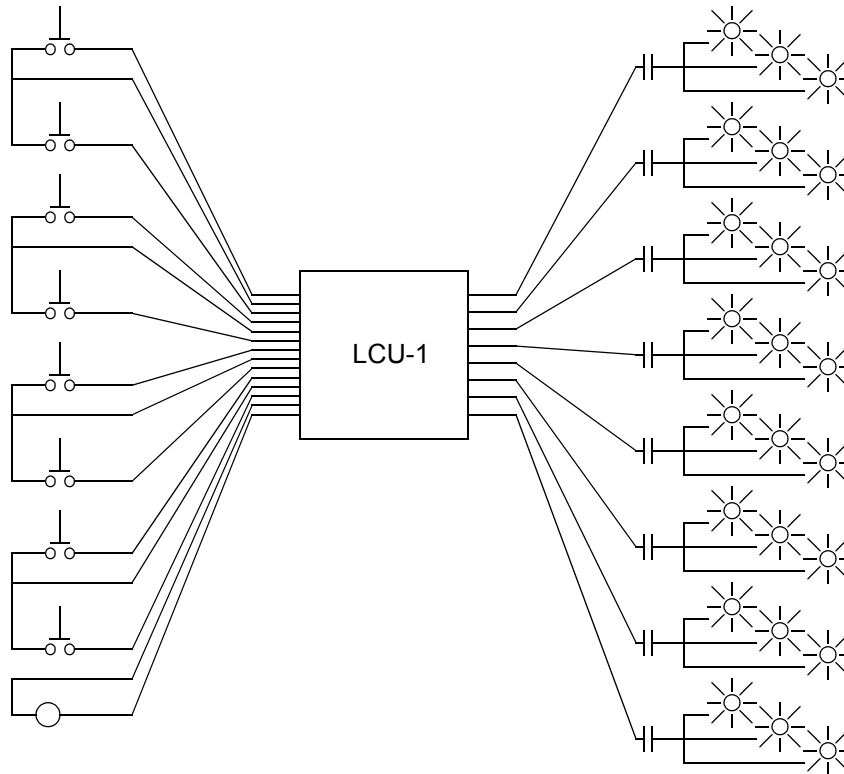

The LCU-1's lighting control algorithms support the following applications or schemes:

- Exterior lighting (signage and parking lot lights)
- Conventional interior lighting
- Energy saving interior lighting
- Energy saving upgrades to interior lighting

Exterior lighting is typically controlled by a photosensor so that the lighting turns on at dusk and off at dawn. Using the LCU-1, a schedule can be added to this scheme so that the lights can shut off automatically in the middle of the night if the area is unoccupied. Physical override switches can also force the lighting on or off on demand.

Conventional interior lighting will have the lights operating from a schedule. The lights turn on at a certain time, and off at another. Physical override switches enable occupants to override the schedule.

Energy saving interior lighting is similar to conventional interior lighting in that the lights turn off according to a schedule, but the lights will remain off until turned on with an override switch. This mode of operation can be compliant with ASHRAE 90.1-1999 and California's Title 24.

Energy saving interior upgrades minimize the rewiring required for lighting control. Conventional light switches are replaced with smart switches, such as model AS-110 from "The Watt Stopper". Control contactors are wired into the lighting circuits. The control system makes the lights available during the "on" times but requires the users to manually turn the lights on. The LCU-1 turns the lights off when scheduled. Occupants can turn the lights back on from the smart switches.

Sequence of Operation

The LCU-1 employs a “zone” system to control lighting circuits. A lighting system can contain up to eight zones. Lighting outputs are assigned to particular zones, and when a zone changes state, all of the outputs for that zone are energized or de-energized. Each zone has its own schedule that defines when a zone is occupied or unoccupied. In general, the lights in an occupied zone are ON, and the lights in an unoccupied zone are OFF. Switch and photosensor inputs are also assigned to zones, and any switch assigned to a zone can override the occupancy status of a zone.

Zones

Zones are virtual groupings of inputs and outputs that are an abstract way of looking at the physical hardware that makes up the lighting system. Switches and contactors that are connected to separate LCU-1s can be linked together by grouping them into zones. When a zone changes status from occupied to unoccupied, all of the lights assigned to that zone turn OFF. Any physical override switch assigned to a zone can override the occupancy of the zone. Switches and contactors can also be assigned to multiple zones.

Scheduling

In iWorX, you define schedules by creating groups in the Local Control Interface (LCI) and configuring when those groups are to be occupied and unoccupied. For HVAC control, you assign individual controllers to groups. For lighting control, you assign *zones* to groups. A group’s schedule will instruct the LCU-1s in the system to turn the lights in a zone ON when the group to which that zone belongs is scheduled to be occupied, and OFF when it is unoccupied.

If the blink warning is enabled for a zone, the zone’s lights will blink five minutes before the zone is scheduled to become unoccupied. Activating an override switch during those five minutes will cause the zone’s lights to stay on for the configurable “override runtime” period.

Switches

Physical switches enable a zone’s occupants to override the scheduled state of the zone. Activating an override switch when the zone is occupied forces the zone’s state to change to unoccupied until the next scheduled occupied period. Activating an override switch when the zone is unoccupied forces the zone’s occupancy status to change to “occupied” for the configurable “override runtime” period.

Three types of switches can be used with the LCU-1.

SPDT Momentary

Typically, this switch looks like a rocker switch. This type of switch actually consists internally of two switches, and both are used to provide input to the LCU-1. The odd input of an SPDT switch is a signal to turn the zone’s lights ON and the even input is a signal to turn the zone’s lights 'OFF'.

SPST Momentary

This switch is usually a “normally open” pushbutton. Pushing the button changes the zone’s occupancy status.

SPST Continuous

Continuous switches usually resemble regular toggle-style light switches. Every change of switch state between “closed” and “open” toggles the zone to its opposite state, like a 3-way switch.

Photosensor Operation

If a photosensor is connected to the system through an LCU-1, any zone in the system can be set to use the photosensor input to determine its occupancy status. The polarity of the photosensor can be switched to match various photosensor hardware types.

A zone can also use a schedule along with the photosensor. If a zone is set to use a timed photosensor, then the zone's lights will be only if *both* the current time is in between the zone's start and stop times **AND** the photosensor indicates that it is dark. The schedule used for timed photosensor operation is the LCU-1's local backup schedule, not the group's schedule.

Distributed LCU-1 Operation

All status and switch information is shared among all LCU-1s on the network. This adds flexibility to the system as several physically separated circuits can be controlled as one zone. Remote override switches can also be located farther from the zones they control, using a local LCU-1 to transmit commands through the network. Lastly, any zone can be controlled by the photosensor, even though only one photosensor can be installed on the network.

Local Backup Schedule

The LCI normally determines the operating mode. You can define a local backup schedule for situations when the LCI is not available. When the controller detects that the LCI is not available (after 10 minutes without communication), it resorts to the local backup schedule that you have configured. If the local backup schedule is disabled, the controller defaults to occupied mode.

You configure the occupied and unoccupied times that are used in determining the current operating mode of the controller when it is running the backup schedule. By default, both the unoccupied and occupied time are set to zero, which disables the local backup schedule. This causes the controller to default to the occupied mode of operation if it cannot communicate with the LCI.

Controller Identification

You need to press the controller's service pin to allow the LCI to identify and configure it. After you press the service pin, the controller's status light will be flashing green until it is configured through the LCI, and will be solid green after it is configured. The controller must be configured by the LCI to allow you to use the LCI to set the controller's schedules, change its setpoints, etc. You need to press the service pin after the controller is installed and the LCI is active on the network.

Troubleshooting

Diagnostic LEDs

The controller has 3 LED indicators. These indicators can aid in troubleshooting equipment operation problems. The following table lists the function of each LED in the order it appears from top to bottom on the unit.

Figure 2: Diagnostic LEDs

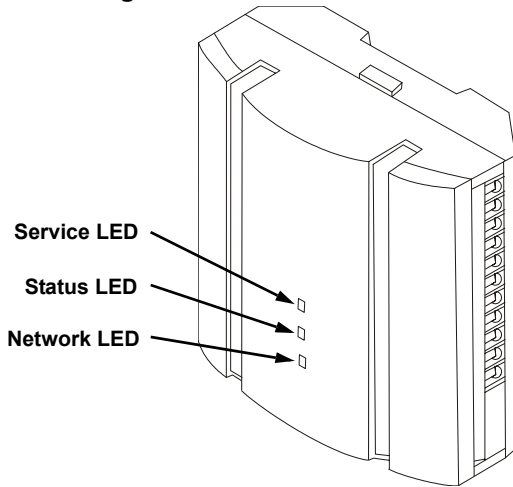

Table 1: Diagnostic LEDs

LED	Indication
Service	Illuminated when the service pin is pushed
Status	Solid green when running and configured by an LCI Flashing green when running and NOT configured by an LCI Flashing yellow when the controller receives a WNK command from the network.
Network	Yellow while the controller is transmitting data onto the FTT-10A network Green when there is network activity Off when there is no network activity

Troubleshooting Tips

Controller is not running and Status LED is not illuminated

No power to controller. Verify the voltage on the controller's power connector (24 VAC). Also verify that the controller is firmly seated in the controller base module.

How do I reset the controller?

The controller can be reset by the LCI, or you can cycle power to the controller. Refer to the LCI documentation for more information on resetting the controller using the LCI.

Status LED flashing even after the LCU-1 is recognized by the LCI

Even after the LCU-1's service pin has been pressed and the signal has been received by the LCI, the Status LED of the LCU-1 will continue to flash green until at least one lighting zone has been configured through the LCI, and the LCU-1 has been added to a lighting zone. Once the configuration is saved in the LCI and the LCI sends zone information to the LCU-1, the LED will display normal status.

The lights do not turn on, though the LCI indicates they are on

Ensure that the controller has been powered with 24 VAC and the lighting outputs have been correctly wired to the coils of the lighting contactors. Also ensure that the contactors have 24 VAC coils.

Lights do not come on as scheduled

There are several reasons the lights may not cycle on and all should be checked.

1. Is the lighting zone part of a group, and is the group occupied?
2. Is a photosensor controlling the lighting zone and is it bright outside?
3. Is a timed photosensor in use? Zones set to use a timed photosensor use the backup schedule that is stored in the LCU-1, not the group's schedule.

Lights will not turn off, even using override switches

- If no backup schedule was set in the LCU-1 and communication with the LCI is lost for more than 10 minutes all lights default to ON. Verify communication between the LCI and LCU-1, and that the LCU has a backup schedule.
- Is the Status LED blinking Green? If so, the LCU has not been configured by the LCI and the default state for the outputs is ON.
- Verify that the switches are configured properly and are each part of a lighting zone.
- If the controller has an improper system time setting, the lights will automatically be turned ON. An improper system time is most often caused by a power outage. The time is usually reset by the LCI, but if the LCU-1 cannot communicate with the LCI, it will have the incorrect time.
- Is the zone override enabled on the LCI? This network override forces all contactors in the zone to ON, which is useful for testing purposes.

Lights are on when they should be off and off when they should be on

Check the contactor polarity through the device setup page of the LCI. Use that page to change the polarity, if necessary.

What is the true meaning of the 3 switch types?

- SPDT Momentary - Uses 2 inputs (switches) to control a lighting circuit. Odd input switches turn the zone 'ON' and even input switches turn the zone 'OFF'.
- SPST Momentary - Pressing the switch changes the zone's occupancy state.
- SPST Continuous - Every change of state toggles the zone to its opposite state, like a 3-way switch.

Photosensor problems

The photosensor must be a switch-type photosensor similar to "The Watt Stopper" model EM-24A2. If you are experiencing problems with the photosensor input verify the following:

- Have you installed more than one photosensor? Only 1 photosensor is allowed for the entire system.
- Is the photosensor enabled?
- Is the polarity inverted on the configuration screen?
- Is a zone configured to use the photosensor?
- Is a contactor in the photosensor controlled zone and is it configured for photosensor operation?

Network Variables and Configuration Variables

This section describes all of the Network and Configuration Variables used in the controller.

Network Variables

Table 2: LCU-1 Inputs

LCI Variable Name	Range	Default Value	Description
System Time	00:00 to 23:59	00:00	System clock value (set by the LCI)
Photosensor Input	Off, On, Undefined	Undefined	Status of the photosensor
Occupancy Cmd [1-8]	Occupied, Unoccupied, Undefined	Undefined	Network override for occupancy

The following output variables are read only and cannot be changed.

Table 3: LCU-1 Status Outputs

LCI Variable Name	Range	Description
Digital Output Status	0 to 255	Status of all outputs as an 8-bit number.
Zone Switch Status [1-8]	Off, On, Undefined	Status of each override switch
Lighting Zone Status [1-8]	Unconfigured, On, Off, Override On, Override Off	The current state of each lighting zone.

Configuration Variables

Table 4: LCU-1 Zone Configuration

LCI Variable Name	Range	Description
Learn	0, 2	Learn mode preset code. Must be set to LN_LEARN_VALUE (2) for this to be accepted. LN_READ_VALUE (0) can be used read a preset back.
Selector	0 to 7	Select which zone is to be configured by the following variables.
Value[0]	Bit 0: use photosensor Bit 1: enable Scheduled On Bit 2: this zone on	Bit field for configuration:
Value[1]	0 to 8	Count of 15 minute intervals in the unoccupied override time.
Value[2]	0 to 23	Hour of ON time
Value[3]	0 to 59	Minute of ON time
Hour	0 to 23	Hour of OFF time
Minute	0 to 59	Minute of OFF time

Table 5: LCU-1 Override Switch Configuration

LCI Variable Name	Range	Description
Learn	0, 2	Learn mode preset code. Must be set to LN_LEARN_VALUE (2) for this to be accepted. LN_READ_VALUE (0) can be used read a preset back.
Selector	0 to 7	Selects which switch is to be configured by the following variables.
Value[0]	0 to 7	8 bits of zone assignment, setting a bit includes this switch as part of that zone.
Value[1]	Bit 0 & 1: Switch configuration: 00 SPST momentary 01 SPDT momentary 10 STST latched Bit7: status lamp on steady.	8 bits of configuration data.

Table 6: LCU-1 Contactor Output Configuration

LCI Variable Name	Range	Description
Learn	0, 2	Learn mode preset code. Must be set to LN_LEARN_VALUE (2) for this to be accepted. LN_READ_VALUE (0) can be used read a preset back.
Selector	0 to 7	Selects which contactor is to be configured by the following variables.
Value[0]	0 to 7	8 bits of zone assignment, setting a bit includes this output as part of that zone
Value[1]	Bit 0: output type 1=using AS-110 switches 0 = normal outputs Bit 1: blink warning 1= disabled 0= enabled Bit 2: Use photosensor Bit 3: Use timed photosensor	Configuration bit field.

Table 7: LCU-1 Photosensor Configuration

LCI Variable Name	Range	Description
Learn	0, 2	Learn mode preset code. Must be set to LN_LEARN_VALUE (2) for this to be accepted. LN_READ_VALUE (0) can be used read a preset back.
Selector	Must be 0	Select which photosensor is to be configured by the following variables.
Value[0]	Bit 0: Invert sensor polarity 0= normal polarity 1 = inverted polarity Bit 1: Disable Lag filter 0= lag filter on 1 = lag filter off Bit 2: Enable Photosensor 0= disable 1= enabled	Configuration bit field.

