

MPU-1

The iWorX MPU-1 is a multiplexed package unit controller that permits a single zone package unit to operate multiple zones. The MPU-1 operates in conjunction with up to 32 multiplexed zone controllers. Control is achieved by multiplexing the primary supply air between cooling and heating based on the various demands from the zone controllers. In addition to multiplexing, the MPU-1 controls an economizer and bypass damper.

Application

The MPU-1 supports analog inputs for return air humidity, mixed air temperature, supply air temperature, and static pressure. Basic to each unit is a removable electronics module with LED indicators. Coupled to this module is a DIN rail or panel-mount base module with wiring terminal blocks.

They function in standalone mode or as part of a LONWORKS® Network using the integral FTT-10 Free Topology communications transceiver. This network interface enables the controllers to be integrated with a building automation system.

The controllers also monitor smoke, air filter, mixed air low limit, fan status, and indoor air quality.

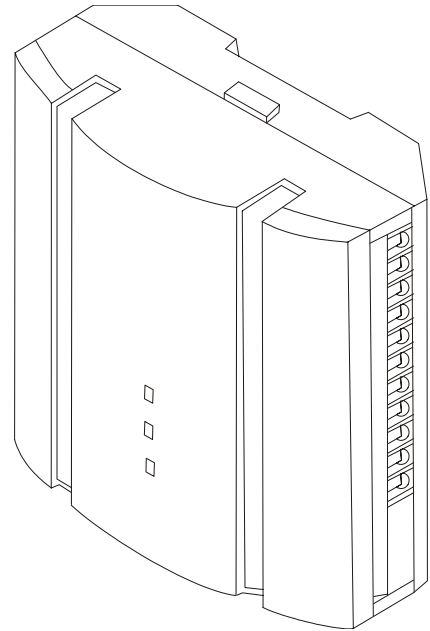

Applicable Documentation

Description	Audience	Purpose
iWorX LCI User's Guide	<ul style="list-style-type: none"> - Application Engineers - Installers - Service Personnel - Start-up Technicians - End user 	Provides instructions for setting up and using the iWorX Local Control Interface.
iWorX MPU-1 Application Manual	<ul style="list-style-type: none"> - Application Engineers - Wholesalers - Contractors 	Provides specific application information about the MPU, including sequence of operation and configuration information.
iWorX VAV-1 Application Manual		Provides specific application information about the VAV-1, including sequence of operation and configuration information.
Additional Documentation	<i>LonWorks FTT-10A Free Topology Transceiver User's Guide</i> , published by Echelon Corporation. It provides specifications and user instructions for the FTT-10A Free Topology Transceiver.	

Typical Use

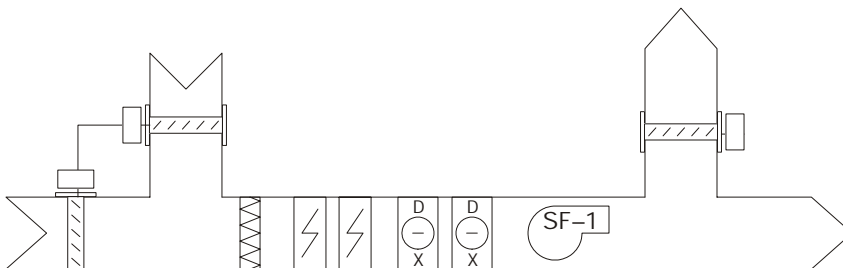

Innovex Technologies
511 Braddock Avenue
Turtle Creek, PA 15145
www.innovextechnologies.com

iWorX is a trademark of Innovex Technologies
LON, LONWORKS, & LONMARK are trademarks of Echelon Corporation

Copyright Notice

This document copyright © 2006, Innovex Technologies. All other intellectual property rights and copyrights related to or arising from these products belong to a third party.

Precautions

General



This symbol is intended to alert the user to the presence of important installation and maintenance (servicing) instructions in the literature accompanying the equipment.



CAUTION: Risk of explosion if battery is replaced by an incorrect type. Contains lithium type battery, dispose of properly.



WARNING: Electrical shock hazard. Disconnect **ALL** power sources when installing or servicing this equipment to prevent electrical shock or equipment damage.

Make all wiring connections in accordance with these instructions and in accordance with pertinent national and local electrical codes. Use only copper conductors that are suitable for 167 °F (75 °C).

Static Electricity

Static charges produce voltages that can damage this equipment. Follow these static electricity precautions when handling this equipment.

- Work in a static free area.
- Touch a known, securely grounded object to discharge any charge you may have accumulated.
- Use a wrist strap when handling printed circuit boards. The strap must be secured to earth ground.

Location

Avoid locations where corrosive fumes, excessive moisture, vibration or explosive vapors are present.

Avoid electrical noise interference. Do not install near large contactors, electrical machinery, or welding equipment.

This equipment is intended for indoor or outdoor use. Preferably, or as required by National Electrical Code, the unit is intended to be installed within an electrical control enclosure. Operate where ambient temperatures do not exceed 185 °F (85 °C) or fall below -40 °F (-40 °C) and relative humidity does not exceed 90%, non-condensing.

For Installation in the United States

This equipment has been tested and found to comply with the limits for a Class A digital device, pursuant to Part 15 of the FCC rules. These limits are designed to provide reasonable protection against harmful interference. This equipment can radiate radio frequency energy and, if not installed and used in accordance with the instructions, may cause harmful interference to radio communications. However, there is no guarantee that interference will not occur in a particular installation. If this equipment does cause harmful interference to radio or television reception, which can be determined by turning the equipment off and on, the user is encouraged to try to correct the interference by one or more of the following measures:

- Reorient or relocate the receiving antenna.
- Increase the separation between the equipment and the receiver.
- Connect the equipment to a power source different from that to which the receiver is connected.
- Consult the equipment supplier or an experienced radio/TV technician for help.

You are cautioned that any changes or modifications to this equipment not expressly approved in these instructions could void your authority to operate this equipment.

For Installation in the European Community

This equipment meets the requirements of the European Community Directives for Electromagnetic Compatibility (EMC Directive 89/336/EE).

Before Installing

About this Document

The instructions in this manual are for the MPU Series modules, which support one multiplexed package unit.

Inspecting the Equipment

Inspect the shipping carton for damage. If damaged, notify the carrier immediately. Inspect the equipment for damage. Return damaged equipment to the supplier.

What is Not Included with this Equipment

- A power source for the equipment electronics and peripheral devices.
- Tools necessary to install, troubleshoot and service the equipment.
- The screws or DIN rail needed to mount the device.
- Peripheral devices, such as sensors, actuators, etc.
- Cabling, cabling raceway, and fittings necessary to connect this equipment to the power source, FTT-10A network and peripheral devices.

Equipment Location



Abide by all warnings regarding equipment location provided earlier in this document.

Optimally, the equipment should be installed within a secure enclosure.

The equipment must be installed indoors unless contained within a protective enclosure. The enclosure must maintain internal temperature and humidity within the ranges specified for this equipment.

The equipment must be installed within 500 feet of all input peripherals (smoke detectors, sensors, etc.) that will be connected to the equipment.

Selecting a Power Source

This equipment requires a UL recognized or CE marked (as appropriate) external power source (not supplied) to operate. The controller power input requires a voltage of 24 volts AC.

To calculate power source current requirements, add the power consumption of all peripheral devices to that of the controller.

The controller and triac output loads can use the same power source. If both are using the same power source, the loads must have EMF protection. This protection can be integral to the load, or installed in the 24 VAC wiring across the load's coil.

To provide necessary RFI and transient protection, the controller's ground (GND) pin (T28) must be connected to earth ground or the earth ground of the packaged unit's enclosure ground. Failure to properly ground the controller may cause it to exceed FCC & CE limits. Excessive noise could also produce inaccurate sensor data. The power source must be capable of operating with the connection to ground described under "Grounding the Device" on page 4.

Installation



Warning: Electrical shock hazard. To prevent electrical shock or equipment damage, disconnect **ALL** power sources to controllers and loads before installing or servicing this equipment or modifying any wiring.

Mounting the Device

1. Select mounting location. Enclosure mounting is recommended.
2. Squeeze the controller at the top and bottom to release the cover tabs, and gently separate the controller base (back) from the electronics module (front).
3. Do one of the following:
 - a. Using two #6 pan head screws, mount base of controller to a panel.
 - b. Snap controller base on a 35 mm DIN mounting rail (not provided). Multiple units can be mounted on the same DIN mounting rail.
4. Wire controller base (See Routing Cabling to the Device).
5. After wiring:
 - a. Line up terminal pins with the correct sockets on the terminal blocks.
 - b. Insert cover tabs into brackets on the base of the controller.
 - c. Push gently until the cover snaps into place.

Figure 1: Mounting Dimensions.

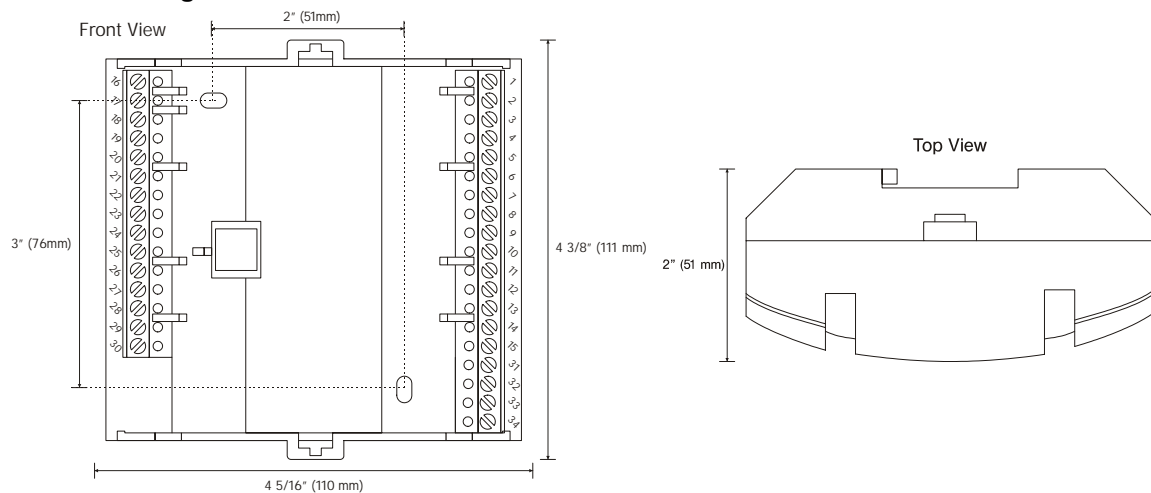

Routing Cabling to the Device



Cabling used to connect the power source and cabling used to connect the FTT-10A network must remain separated within the control enclosure and wiring conduit.

Grounding the Device



The ground terminal (T28) must be securely connected to earth ground. Failure to properly ground this equipment will result in improper operation. Improper grounding may also increase the risk of electrical shock and may increase the possibility of interference with radio/TV reception.



For best performance, connect the power supply common terminal (T2) to the same external point as the ground terminal (T28).

Wiring Information



WARNING: Terminals 2, 17, 20, 23, 26, and 32 are connected internally on all MPU Series controllers. Disconnect **ALL** power sources when installing or servicing this equipment to prevent electrical shock or equipment damage.

Figure 2: MPU-1 Terminal Connections

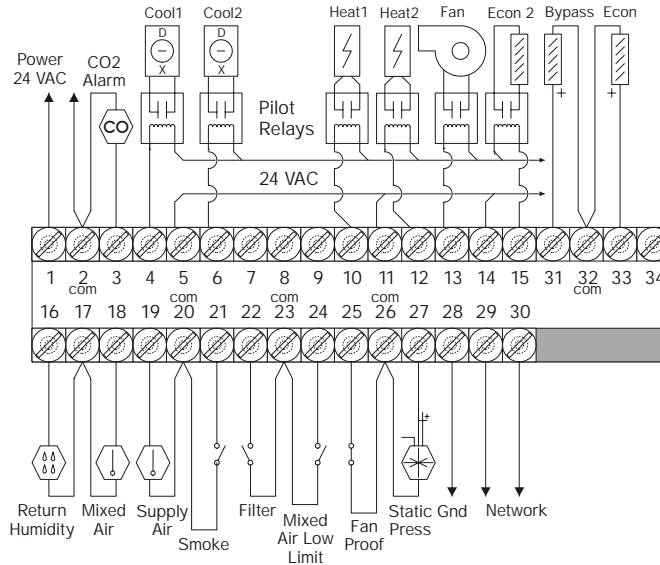

Connecting Input Devices

Internal Air Quality Alarm Sensor (IAQ)

To connect the digital CO₂ level sensor to the unit, attach one wire from the sensor to IAQ (T3) and the other wire to the adjacent common (T2). The sensor must provide a contact closure when the CO₂ limit is exceeded.

Return Humidity (RAH) (Optional)

To connect the Return Air Humidity sensor to the unit, connect the positive wire from the sensor to RAH (T16) and the other wire to the adjacent common (T17). The sensor must be of the 0-10 Volt type.

If global indoor air humidity readings are being provided over the network, it is not necessary to attach a return air humidity sensor directly to the MPU. See the *iWorX MPU-1 Application Manual* for more information.

Mixed Air (MAT)

To connect the Mixed Air thermistor to the unit, attach one wire from the thermistor to MAT (T18) and the other wire to the adjacent common (T17). The thermistor used must be 10K Precon Type III.

Supply Air (SAT)

To connect the Supply Air thermistor to the unit, attach one wire from the thermistor to SAT (T19) and the other wire to the adjacent common (T20). The thermistor used must be 10K Precon Type III.

Smoke Detector (SMK)

To connect the smoke detector switch to the digital input, attach one wire of the contact to SMK (T21) and the other wire to the adjacent common (T20). This must be a dry contact normally open switch. This input is for indication only. A separate smoke detector should be wired into a fire alarm system if the generation of a fire alarm is required.

Filter (FIL)

To connect the filter switch to the digital input, attach one wire of the contact to FIL (T22) and the other wire to the adjacent common (T23). This must be a dry contact normally open switch.

Mixed Air Low Limit Indication (MLL)

To connect the low limit indication switch to the digital input, attach one wire of the contact to MLL (T24) and the other wire to the adjacent common (T23). This must be a dry contact normally open switch.

Fan Proof (FNP)

To connect the fan proof switch to the digital input, attach one wire of the contact to FNP (T25) and the other wire to the adjacent common (T26). This must be a dry contact, normally closed switch. If you are not providing a fan proof input, T25 and T26 must be shorted (jumpered) together.

Static Pressure (SPR)

To connect the static pressure sensor to the analog input, attach the positive wire from the sensor to SPR (T27) and the other wire to the adjacent common (T26). The sensor must be analog, 0 to 10 VDC, scaled.

Connecting Output Devices**Cooling Stages 1 & 2 (C1, C2)**

The cooling stage outputs must be connected to 24 VAC pilot relays. See Figure 2 on page 5 for details.

Heating Stages 1 & 2 (H1, H2)

The heating stage outputs must be connected to 24 VAC pilot relays. See Figure 2 on page 5 for details.

Fan Start/Stop (FAN)

The fan output must be connected to a 24 VAC pilot relay. See Figure 2 on page 5 for details.

Two-position Economizer (ECD)

The digital economizer output must be connected to a 24 VAC pilot relay. See Figure 2 on page 5 for details.

Bypass Damper (BYP)

The bypass damper output can be set to 0-10 VDC max through the control logic. Connect the positive wire from the damper actuator to BYP (T31) and the other wire to the adjacent common (T32). See Figure 2 on page 5 for details.

Modulated Economizer (ECA)

The modulated economizer output can be set to 0-10 V max through the control logic. Connect the positive wire from the damper actuator to ECA (T33) and the other wire to the adjacent common (T32). See Figure 2 on page 5 for details.

Other Connections**Network (LON)**

Network wiring must be twisted pair. One network wire must be connected to one LON (T29) terminal and the other network wire must be connected to the other LON (T30) terminal. Polarity is not an issue since an FTT-10A network is used for communications.

Power (PWR)

Connect one output wire from a 24 VAC power supply to PWR (T1) and the other output wire from the power supply to the adjacent common terminal (T2).

Ground (GND, COM1)

Terminals COM1 (T2) and GND (T28) must be connected to earth ground. Failure to properly ground this equipment will result in improper operation. Improper grounding may also increase the risk of electrical shock, and may increase the possibility of interference with radio and TV reception.

Specifications

Electrical

Inputs

- Cabling: twisted shielded pair, 18 AWG recommended—500 feet max. (152 meters)
- Resolution: 10 bit

Freeze Indication, Filter Status, Smoke Detect, Local IAQ Alarm

- Dry Contact
- Normally Open
- 5 Volts DC Max

Fan Status

- Dry Contact
- Normally Closed
- 5 Volts DC Max

Return Air Humidity, Static Pressure

- 0 - 10 Volts DC

Mixed Air Temperature, Supply Air Temperature

- Precon Type III 10K thermistor

Outputs

Fan Start/Stop, Heating Stage 1, Heating Stage 2, Cooling Stage 1, Cooling Stage 2, Two-position Economizer

- 24 Volts AC
- 1 Amp at 50 °C, 0.5 Amps at 85 °C

Modulated Economizer, Bypass Damper

- 0-10 Volts DC
- 2K Ohm minimum load
- 8 bit resolution

FTT-10A Network

- Speed: 78 KBPS
- Cabling: Maximum node-to-node distance: 1312 feet (400 meters)
- Maximum total distance: 1640 feet (500 meters)
- 42.4 Volts DC max

Table 1: Network Wire Specifications

Cable Type	Pairs	Details	Connect Air Catalog No.
Level 4 22AWG (0.65mm)	1	Unshielded, Plenum, U.L. Type CMP	W221P-2001
Level 4 22AWG (0.65mm)	1	Unshielded, Non-Plenum, U.L. Type CM	W221P-1002

For detailed specifications, refer to the FTT-10A Free-Topology Transceiver User's Guide published by Echelon Corporation. For information on ordering Connect Air items, contact Connect Air International; 4240 B Street; Auburn, WA 98001 <www.connect-air.com>.

Power

Power Requirements

- 24 VAC nominal (requires an external supply)

Power Consumption

- With no external loads: 15 VA

Mechanical

Housing

- Dimensions: 4 3/8" high, 4 5/16" wide, 2" deep (111 mm high, 110 mm wide, 51 mm deep)
- ABS Polycarbonate

Weight

- Controller Weight: 0.45 pounds (0.22 kilograms)
- Shipping Weight: 0.60 pounds (0.28 kilograms)

Electronics

- Processor: 3150 Neuron 10 MHz
- Flash: 48 Kilobytes
- SRAM: 8 Kilobytes
- Termination: 0.197" (5.0 mm) Pluggable Terminal Blocks, 14-22 AWG

Environmental

- Temperature: -40 °F to 185 °F (-40 °C to 85 °C)
- Humidity: 0 to 90%, non-condensing

Agency Listings

- UL 916

Agency Compliances

- FCC Part 15 Class A
- CE

Troubleshooting

Diagnostic LEDs

The controller has 3 LED indicators. These indicators can aid in troubleshooting equipment operation problems. The following table lists the functions of the controller's LEDs in the order they appear from top to bottom on the unit.

Table 2: Diagnostic LEDs

LED	Indication
Service	– Illuminated when the service pin is pushed
Status	– Solid green when running and configured by an LCI – Flashing green when running and NOT configured by an LCI – Solid red when a fault condition exists
Network	– Yellow while the controller is transmitting data onto the FTT-10A network – Green when there is network activity – Off when there is no network activity

Figure 3: Diagnostic LEDs

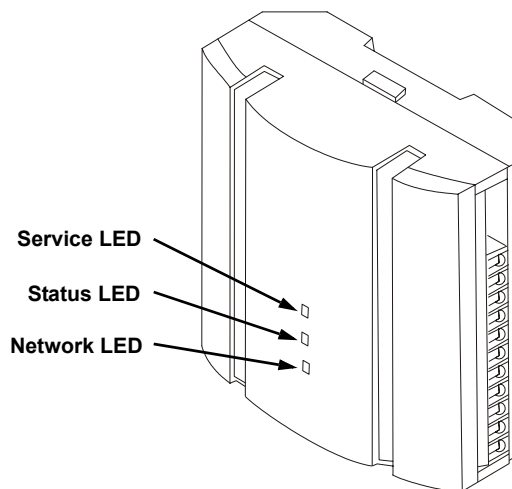

Troubleshooting Tips

Controller is not running and Status LED is not illuminated.

No power to controller. Verify the voltage on the controller's power connector (24 VAC).

How do I reset the controller?

The controller can be reset by the LCI, or you can cycle power to the controller. Refer to the LCI documentation for more information on resetting the controller using the LCI.

Can my iWorX system contain multiple MPU controllers?

Yes, provided that you do not exceed the maximum number of controllers that can be handled by the Local Control Interface (LCI).

Can I reverse the minimum and maximum values for the bypass damper?

Yes. This will result in reverse damper action.

Can I use the bypass damper outputs to control a VFD instead?

Yes.

Thermistor readings fluctuate rapidly, sometimes by several degrees.

The controller is not properly grounded. The controller's ground (GND) pin (T28) must be connected to earth ground.

