

### VAV-1

The VAV-1 Variable Air Volume Zone Unit is a stand-alone microprocessor-based controller for pressure independent VAV terminal units. The VAV-1 is capable of communications on a LONWORKS network for monitoring and control purposes. The VAV-1 is used to control commercial unitary heating, ventilating, and air conditioning (HVAC) equipment. It performs a wide range of VAV terminal box applications.

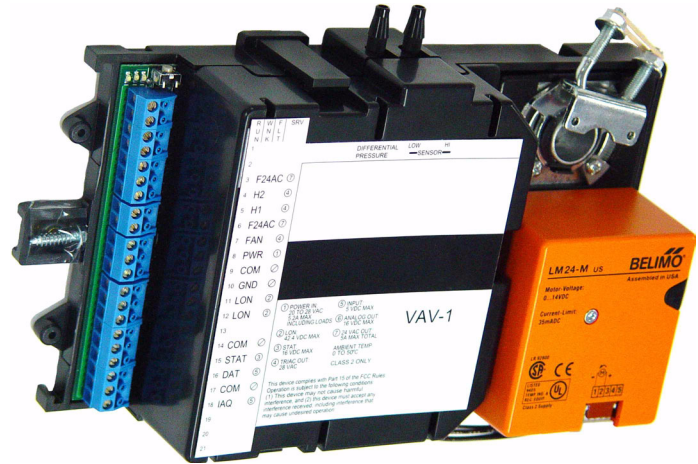

### Overview

A digital input is provided for an indoor air quality alarm. An analog input is provided for a discharge air temperature sensor. A two-wire serial interface is provided for the thermostat. The controller incorporates digital outputs in the form of triacs for fan start/stop and two heating stages or heating valve open/close.

The controller is based on LONWORKS® networking technology. It can be networked to a higher-level control system for monitoring and control applications.

### Features

- On-board air-flow sensor
- Integral damper actuator
- Optional indoor air quality (IAQ) alarm input (contact closure)
- Optional discharge air temperature (DAT) monitoring
- Two stages of electric reheat or floating setpoint hot water reheat valves
- Option to use auxiliary local heat sources for first stage of heating
- Parallel or series fan
- Pressure independent flow control
- Networking of multiple units
- Individual temperature setpoints for occupied/unoccupied heating
- Networked operation using LONWORKS Technology
- Thermostat with space temperature, setpoint adjust, occupancy override
- Integrates with Multiplex Package Unit controller (MPU-1)
- Integrates with Variable Air Volume Package Unit controller (VPU-1)
- “Stand Alone Mode” for independent operation
- Air quality compensation
- Automatic configuration with the Local Control Interface (LCI)
- Alarm/Event reporting



Innovex Technologies  
511 Braddock Avenue  
Turtle Creek, PA 15145  
[www.innovextechnologies.com](http://www.innovextechnologies.com)

iWorX is a trademark of Innovex Technologies  
LON, LONWORKS, & LONMARK are trademarks of Echelon Corporation

## Purpose of This Guide

The *iWorX VAV-1 Application Manual* provides application information for the VAV-1 controller.

The reader should understand basic HVAC concepts, intelligent environmental control automation, and basic LONWORKS networking and communications. This Application Manual is written for:

- Users who engineer control logic
- Users who set up hardware configurations
- Users who change hardware or control logic
- Technicians and field engineers

## Copyright Notice

This document copyright © 2006, Innovex Technologies. All other intellectual property rights and copyrights related to or arising from these products belong to a third party.

The confidential information contained in this document is provided solely for use by Innovex Technologies employees, licensees, and system owners, and is not to be released to, or reproduced for, anyone else. Neither is it to be used for reproduction of this control system or any of its components.

All specifications are nominal and may change as design improvements occur. Innovex Technologies shall not be liable for damages resulting from misapplication or misuse of its products.

## Applicable Documentation

Part Number	Description	Audience	Purpose
iWorX-VAV-INS-100	iWorX VAV Series Installation Instructions	<ul style="list-style-type: none"> <li>– Application Engineers</li> <li>– Installers</li> <li>– Service Personnel</li> <li>– Start-up Technicians</li> </ul>	Provides instructions for setting up and using the iWorX VAV-1 Controller.
iWorX-MPU1-APP-100	iWorX MPU-1 Application Manual	<ul style="list-style-type: none"> <li>– Application Engineers</li> <li>– Wholesalers</li> <li>– Contractors</li> </ul>	Provides specific application information about the MPU-1, including sequence of operation and configuration information.
iWorX-VPU1-APP-100	iWorX VPU-1 Application Manual		Provides specific application information about the VPU-1, including sequence of operation and configuration information.
iWorX-LCI1-USR-100	iWorX LCI User's Guide	<ul style="list-style-type: none"> <li>– Application Engineers</li> <li>– Installers</li> <li>– Service Personnel</li> <li>– Start-up Technicians</li> </ul>	Provides instructions for setting up and using the iWorX Local Control Interface.
iWorX-DTM-INS-100	iWorX DTM Series General Instructions	<ul style="list-style-type: none"> <li>– End User</li> </ul>	Provides step-by-step installation and checkout procedures for iWorX Digital Thermostat Modules. Also contains instructions for sensor operation.
Additional Documentation	<i>LonWorks FTT-10A Free Topology Transceiver User's Guide</i> , published by Echelon Corporation. It provides specifications and user instructions for the FTT-10A Free Topology Transceiver.		

## Application Description

The VAV-1 maintains the temperature of a space to a user-defined setpoint. Figure 1 and Figure 2 illustrate typical zone applications. Control is achieved by modulating the amount of airflow through the primary damper. In addition, the VAV-1 can control series or parallel fans, floating-setpoint hot water reheat valves, and electric reheat.

**Figure 1: VAV-1 with Electric Reheat and Fan**

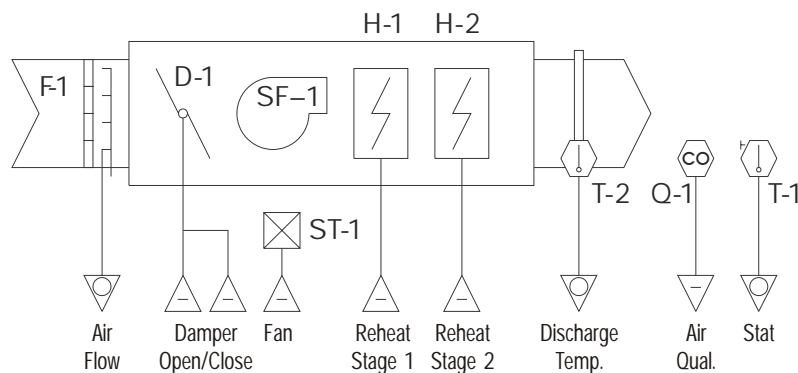

The VAV-1 controls airflow by modulating the primary damper. The controller monitors the air temperature in the space using an attached digital thermostat module (DTM). The algorithm is based on the space temperature input, cooling setpoint, heating setpoint, minimum airflow, and maximum airflow.

The VAV-1 operates in the cooling mode when the primary air source is providing cooled air and the supply air temperature is below the current space temperature. The controller modulates the damper to provide the required amount of cooling to the space. When the space temperature is below the cooling setpoint, the controller closes the damper to maintain the minimum airflow setpoint. As the zone temperature rises above the cooling setpoint the airflow setpoint is regulated between the minimum and maximum airflow setpoints.

If the space temperature drops below the heating setpoint during primary cooling mode, local reheat can be activated to heat the space. The reheat may be accomplished via electric reheat or floating-setpoint hot water reheat valves. The controller can modulate a floating-setpoint hot water valve actuator based on its full-stroke travel time and a calculated desired position. The desired position is calculated by a Proportional + Integral (PI) control algorithm based on the zone temperature and a heating setpoint. The heating stages are sequenced on and off with a time-proportioned control algorithm to minimize excessive cycling.

The VAV-1 operates in the primary heating mode when the primary air source is providing heated air and the supply air temperature is above the current space temperature. When the space temperature is above the heating setpoint, the controller closes the damper to maintain the minimum airflow setpoint. As the zone temperature drops below the heating setpoint the airflow setpoint is regulated between the minimum and maximum airflow setpoints. The damper is modulated to provide the required amount of heating to the space.

The VAV-1 operates in ventilation mode when the primary air source is not providing heated or cooled air. In this mode, the damper is modulated to 55% of the total of the minimum flow plus the maximum flow.

The VAV-1 operates in one of two occupancy states: occupied or unoccupied. The active occupancy state is determined by the LCI. During the occupied period, the VAV-1 maintains the comfort level to user-defined heating and cooling setpoints. During the unoccupied period, the heating setpoint is set back and the cooling setpoint is set up by a user-defined amount.

The series fan is energized during the occupied periods. It is off during unoccupied periods, unless the control calls for heating or cooling.

During occupied periods, the parallel fan is energized when air flow drops below a programmable set-

point, or when the zone temperature drops below the heating setpoint. During standby and warm-up periods, the fan is temperature controlled. The parallel fan is always off during unoccupied periods.

The fan will always be used as the first stage of reheat.

**Figure 2: VAV-1 with Modulated Reheat and Fan**

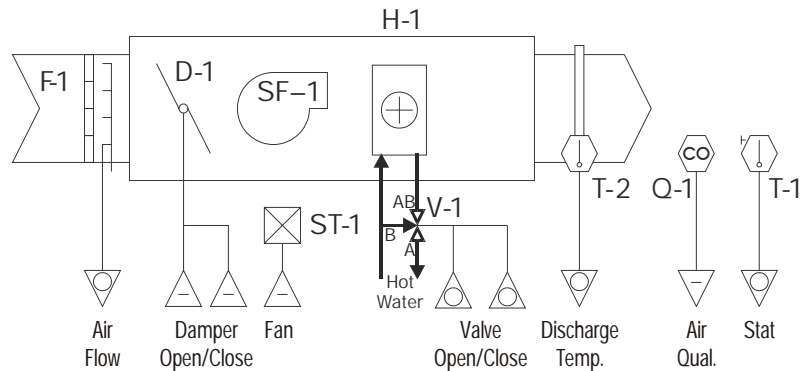

A local CO<sub>2</sub> sensor connected directly to the VAV-1 can be used to monitor the Indoor Air Quality (IAQ). In addition, the VAV-1 can participate in system wide IAQ operation initiated by the primary air source controller. When a local IAQ alarm condition exists, the VAV-1 reports the condition to the primary air source controller. The primary air source controller provides fresh air to the zone by turning on the system fan and modulating the economizer. The primary air source controller signals the VAV-1 to begin IAQ alarm operation.

During IAQ alarm operation, the VAV-1 opens the damper to the maximum flow setpoint. The temperature setpoints are reset to allow the space temperature to rise or drop a configurable limit from setpoint. This permits fresh airflow into to the zone even if the temperature setpoints are exceeded. If the IAQ sensor is connected directly, an IAQ alarm is reported to the LCI.

In stand alone mode, the VAV-1 functions independently from the central HVAC system and is not associated with any master device. It assumes that only cool air is being provided by the central HVAC system, and provides local heating as necessary without communicating demand to any master controller.

When a “heating failed” alarm is received from the primary air controller, the VAV-1 modulates its damper to the maximum airflow position.

If the space temperature exceeds a programmable limit, a “high limit” alarm is reported to the LCI. If the space temperature drops below a programmable limit, a “low limit” alarm is reported to the LCI. When the space temperature returns to the proper range, a “return to normal” message is generated.

## Sequence of Operation

This section describes the detailed sequence of operation for the VAV-1 zone control.

### Operational Mode

The VAV-1 operates in four operating modes: primary heating, primary cooling, primary fan only, and primary off.

The VAV-1 operates as a stand alone unit until it is grouped under a primary source device at the LCI. In stand alone mode, the VAV-1 functions independently from the central HVAC system and is not associated with any master device. It assumes that only cool air is being provided by the central HVAC system, and provides local heating as necessary without communicating demand to any master controller.

Once the VAV-1 is grouped under a master device that controls the primary air source HVAC equipment, that master device determines the current operating mode. The operational mode information is periodically transferred to the VAV-1 over the communications network. The following information is transferred to the VAV-1 from the primary air source controller:

- Operational Mode (primary cool, primary heat, primary off, primary fan only)
- Alarm Conditions (IAQ Mode, Heat Failed On)
- Occupancy Mode (occupied, unoccupied)
- Supply Air Temperature

The primary air source device determines the operational mode based on the zone demand information supplied by each of the VAV-1 zone controllers. Each VAV-1 periodically transfers its zone demand information to the primary air source controller over the communications network. The following information is transferred to the primary air source controller:

- Space Temperature
- Calculated Heating Setpoint
- Calculated Cooling Setpoint
- IAQ Sensor Status (normal, alarm)
- Local Alarm (VAV-1 shutdown)
- Occupancy Mode (occupied, unoccupied, occupied extension)
- Supplemental Heat Status (on, off)

### Occupancy Mode

A remote device on the network normally provides the current occupancy mode. There are two modes of occupancy: occupied and unoccupied. A pushbutton on the local digital thermostat module (DTM) can be used to force the occupancy mode from unoccupied to occupied.

## Setpoint Calculations

The heating and cooling setpoint for both occupied and unoccupied periods are programmable values. The effective setpoint is a calculated value based on the programmed heating setpoint, cooling setpoint and current occupancy mode (i.e. occupied or unoccupied).

The effective setpoint is derived by first calculating the zero energy band (zeb) for the current occupancy state. The zero energy band is then added to the appropriate heating setpoint.

### OCCUPIED:

$$ZebOcc = OccupiedCoolSp \angle OccupiedHeatSp$$

$$EffectiveSp = OccupiedHeatSp + \frac{ZebOcc}{2}$$

### UNOCCUPIED:

$$ZebUnocc = UnoccupiedCoolSp \angle UnoccupiedHeatSp$$

$$EffectiveSp = UnoccupiedHeatSp + \frac{ZebUnocc}{2}$$

**Figure 3: Effective Setpoint Calculation**

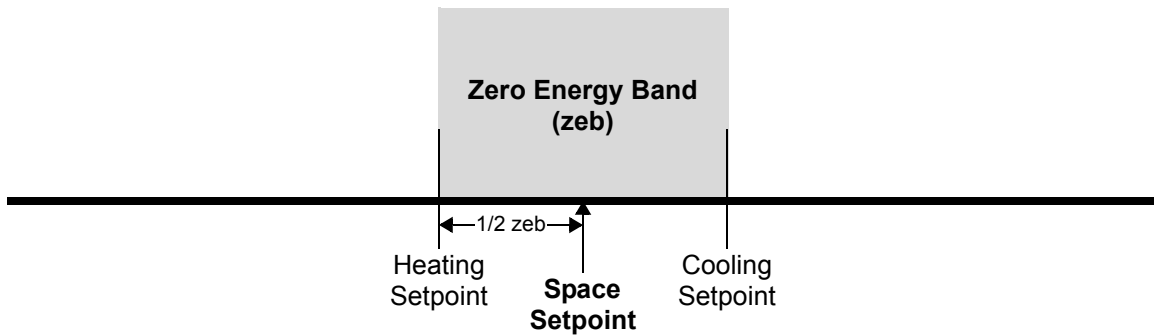

The thermostat setpoint offset is used to increase or decrease the effective setpoint from the local thermostat. The offset value is limited to plus or minus the programmed setpoint adjustment.

The setpoint offset also affects the calculated heating and calculated cooling setpoints by an equal amount. The setpoint offset only applies in the occupied period. It has no effect in the unoccupied period. Note that the actual programmed heating and cooling setpoints are not changed. The offset is simply added to the programmed setpoints to derive the calculated values.

### OCCUPIED:

$$CalcCoolingSp = OccupiedCoolingSp \pm SpOffset$$

$$CalcHeatingSp = OccupiedHeatingSp \pm SpOffset$$

$$EffectiveSp = EffectiveSp \pm SpOffset$$

### Unoccupied:

$$CalcCoolingSp = UnoccupiedCoolingSp$$

$$CalcHeatingSp = UnoccupiedHeatingSp$$

**Figure 4: Setpoint Adjustment Examples**

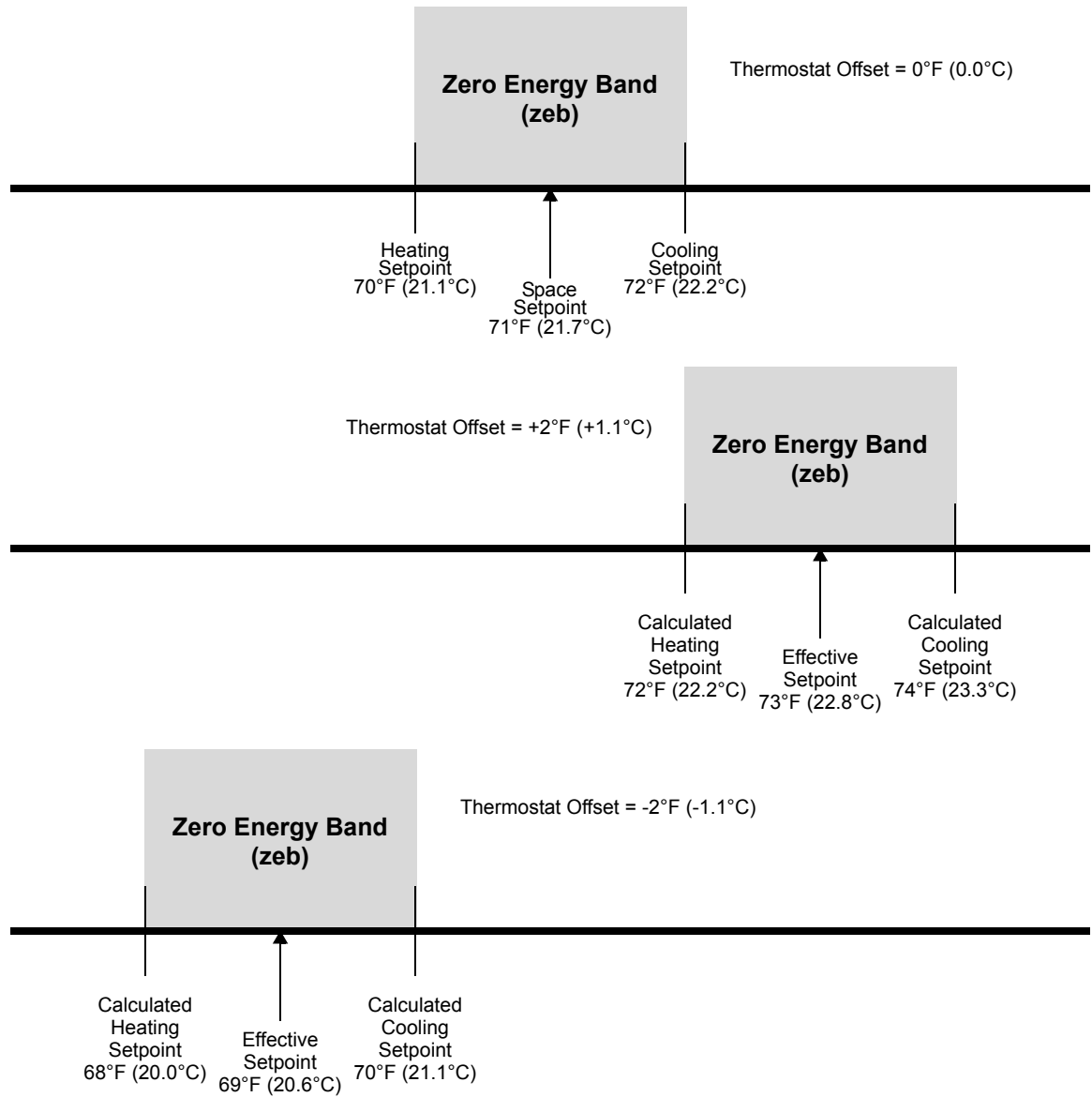

## Damper Control

The primary air damper actuator is controlled based on the current operating mode, space demand and occupancy mode. During the occupied period when the primary air source is cooling, the damper will operate in the primary cooling mode. When the primary air source is heating, the damper will operate in the primary heating mode. During ventilation mode, the damper follows a special rule; see “Ventilation Mode Operation” on page 9.

Zone overheating and overcooling are prevented by keeping the damper closed until the supply air temperature is at least 4 °F (2.22 °C) degrees below the current zone temperature (for cooling mode) or 4 °F (2.22 °C) degrees above the current zone temperature (for heating mode).

During the unoccupied period, the calculated heating and cooling setpoints are set to their unoccupied values. The damper control is the same as the occupied mode. However, when the space temperature is between the calculated cooling and heating setpoints and the zone demand has been satisfied, the damper will be fully closed.

**Figure 5: Occupied Damper Control**

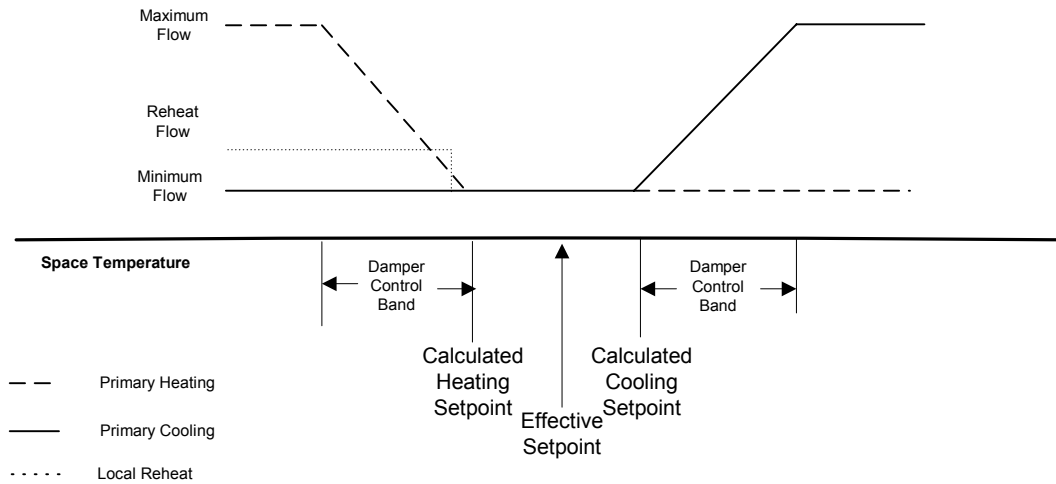

**Figure 6: Unoccupied Damper Control**

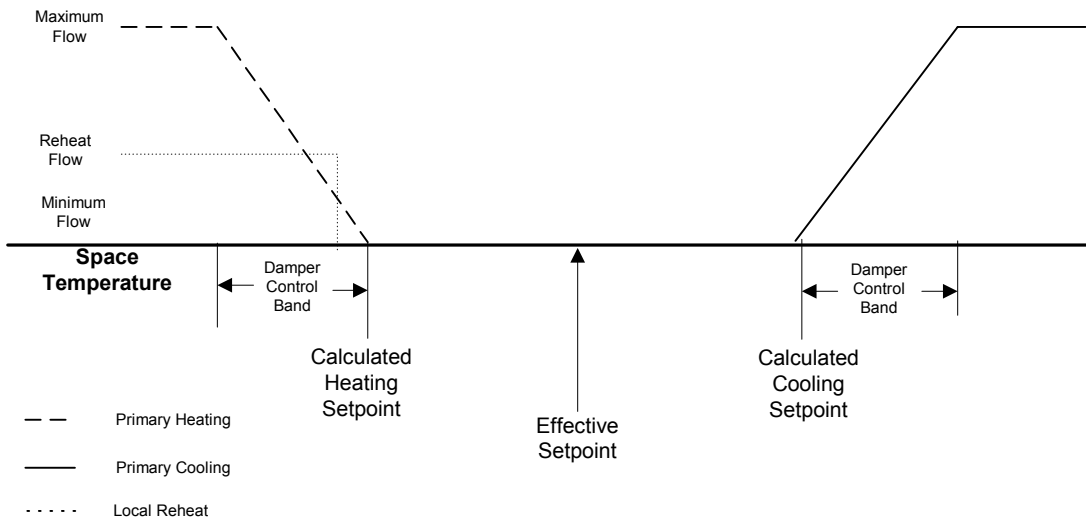

## Primary Cooling Damper Operation

During primary cooling mode the primary air source will supply cool air to the zones. A control loop is used to calculate a required airflow setpoint to satisfy the space demand. The calculation is based on the space temperature, calculated cooling setpoint and calculated heating setpoint (space demand). The damper is then modulated to maintain the calculated airflow setpoint.

As the space temperature rises above the calculated cooling setpoint, the VAV-1 enters the cooling mode. The control loop regulates the calculated airflow setpoint over a range defined by the damper control band. When the space temperature is above the damper control band, the control loop will maintain the maximum flow setpoint.

When the space temperature is at or below the calculated cooling setpoint, the control loop will maintain the minimum flow setpoint. The minimum flow will be maintained as long as the space temperature remains between the calculated cooling and heating setpoints.

As the space temperature drops below the calculated heating setpoint, the VAV-1 enters the local heating mode. If local reheat has been configured and a reheat flow setpoint has been defined, the control will maintain the reheat flow setpoint.

During unoccupied periods, the minimum flow setpoint is set to zero. This allows the damper to close completely when the space demand has been satisfied.

## Primary Heating Damper Operation

During primary heating mode the primary air source will supply warm air to the zones. A control loop is used to calculate a required airflow setpoint to satisfy the space demands. The calculation is based on the space temperature and calculated heating setpoint (space demand). The damper is then modulated to maintain the calculated airflow setpoint.

As the space temperature drops below the calculated heating setpoint, the VAV-1 enters the heating mode. The control loop regulates the calculated airflow setpoint over a range defined by the damper control band. When the space temperature is below the damper control band, the control loop will maintain the maximum flow setpoint.

When the space temperature is at or above the calculated heating setpoint, the control loop will maintain the minimum flow setpoint.

During unoccupied periods, the minimum flow setpoint is set to zero. This allows the damper to close completely when the space demand has been satisfied.

## Ventilation Mode Operation

When the primary source controller is in "Primary Fan Only" or "Primary Off" modes, the damper maintains air flow for ventilation purposes. The VAV-1 will not enter ventilation mode if the primary air source controller is in "Primary Fan Only" mode and the VAV-1 is in local heating mode. The primary air source controller can also override ventilation mode by placing the VAV-1 into Indoor Air Quality (IAQ) mode.

In ventilation mode, the damper will be modulate according to the following equation:

$$Flow = 0.55 \times (MinimumFlow + MaximumFlow)$$

For instance, if the minimum flow is zero, and the maximum flow is 500 CFM, 55% of 500 is 275, so the damper is modulated to provide 275 CFM of airflow.

In order to reduce overheating and overcooling of the zone, the damper does not open for ventilation mode until the supply air temperature is between 65 and 80 °F (18.33 and 26.66 °C).

## Damper Actuator Control

The VAV-1 supports an integral floating-setpoint actuator for controlling the damper position. The actuator has a contact for opening the damper and a contact for closing the damper. The controller will modulate the floating-setpoint damper actuator to maintain the calculated flow setpoint. An integral flow transducer on the VAV-1 measures the primary airflow.

When the primary airflow is below the calculated flow setpoint, the damper open contact will be closed and the damper close contact will be open. When the primary airflow is above the calculated flow setpoint, the damper close output will be closed and damper open contact will be open. Both contacts will be open when the primary airflow equals the calculated flow setpoint. A dead band is provided around the calculated flow setpoint to prevent unnecessary movement of the damper due to minor flow fluctuations. When the calculated flow setpoint is zero, the control will drive the damper closed for the actuator travel time to insure that the damper has closed completely.

**Figure 7: Damper Actuator Control**

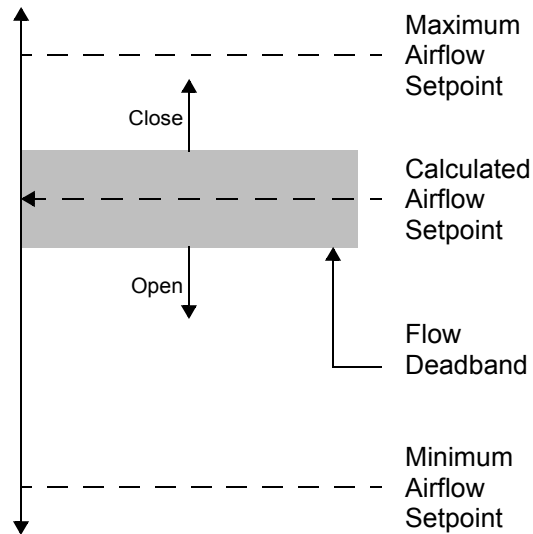

## Local Heating

The heating stages are controlled based on the space temperature, calculated heating setpoint, heating control band and operational mode. The VAV-1 provides the following heating options:

- None
- 1 stage electric
- 2 stage electric
- Floating setpoint valve

Heating can be either reheat, supplemental heat, or auxiliary heating. Reheat is when the operational mode is cooling, the supply air is cool and the space needs heating. Supplemental heat is a way to provide additional heat when the operational mode is heating and supply air is warm. Auxiliary heating uses local auxiliary heat sources as first stage heating without communicating a heating demand to the central HVAC system.

### Electric Heating Stages

During primary cooling mode, when the space temperature drops below the calculated heating setpoint, the VAV-1 enters reheat mode. If the space temperature drops below the heating control band for a predefined period of time, the first stage is turned on. If the space temperature remains below the heating control band for an additional period of time, the second stage is turned on. As the space temperature rises above the calculated heating setpoint for a predefined period of time, the second stage is turned off. If the space temperature remains above the calculated heating setpoint for an additional period of time, the first stage is turned off. When the zone temperature rises above the zone setpoint all of the heating stages will immediately turn off. During local heating, the damper will modulate to the reheat flow setpoint. Reheat is interlocked with the parallel fan operation if it has been configured. The parallel fan will act as the first stage of heating. Therefore, the reheat stages will wait one time interval so that the fan can provide heat to the space first.

During primary heating mode, when the space temperature drops below the calculated heating setpoint and the primary airflow is at its maximum, the VAV-1 enters supplemental heating mode if it is enabled. The heating is cycled on in the same manner as reheat. The parallel fan is not available as the first stage of heat during supplemental heating operation.

During primary off and primary fan only modes the local heating is disabled.

**Figure 8: Electric Reheat**

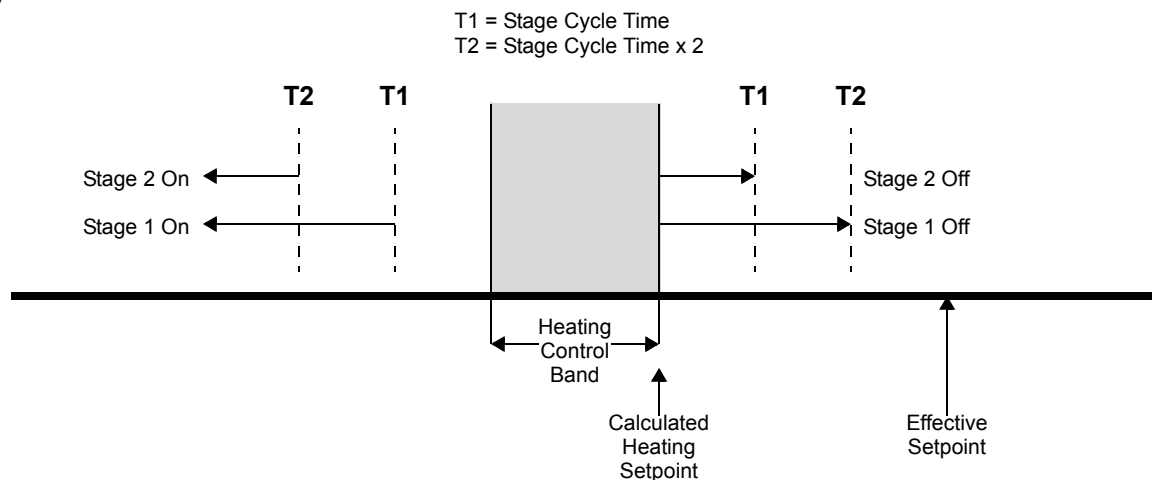

## Modulated Hot Water Valve Reheat

The hot water valve is modulated based on zone temperature. During primary cooling mode, when the zone temperature is above the heating setpoint the reheat valve will be closed. As the zone temperature drops below the heating setpoint a reverse acting control loop modulates the valve position. The position is calculated over a band equal to the heating control band. When the zone temperature is below the heating control band, the valve will be at the maximum reheat position.

During primary heating mode, when the space temperature drops below the calculated heating setpoint and the primary airflow is at its maximum, the VAV-1 enters supplemental heating mode if enabled. The heating valve is modulated in the same manner as reheat. The parallel fan is not available as the first stage of heat during supplemental heating operation.

During primary off and primary fan only modes the local heating is disabled.

**Figure 9: Modulated Reheat Valve**

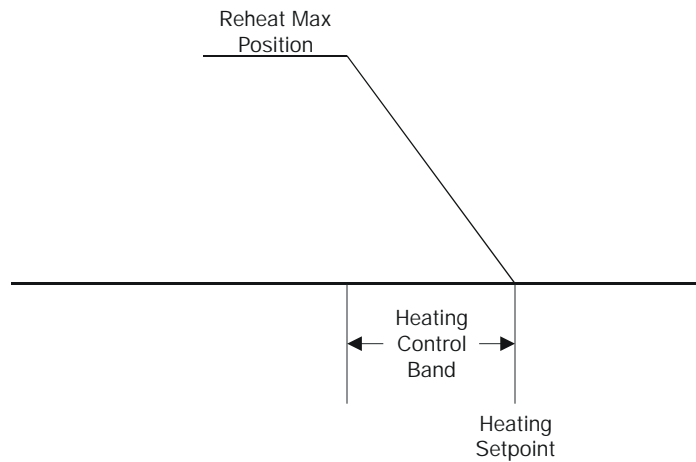

## Auxiliary Heating Mode

The VAV-1 can use auxiliary heat such as radiant floor heat or fin-tube as first stage heating without communicating a heating demand to the central HVAC system. In this mode, the controller's parallel fan output is used as the auxiliary heat output. (The controller's *Fan Type* must be set to "Temperature Controlled Parallel".) If additional heating is needed, second-stage demand is communicated to the central system as described under "Electric Heating Stages" on page 11.

## Parallel Fan

There are two programmable modes of operation for the parallel fan terminal units: flow-controlled and temperature-controlled. In flow-controlled operation, the fan will energize if the air flow drops below a programmable setpoint during occupied periods. During standby periods and occupied temperature-controlled operation, the fan will turn on if the zone temperature drops below the heating setpoint. During unoccupied periods, the fan will not energize.

### Temperature Controlled Parallel Fan Operation

During occupied periods when the operational mode is primary cooling, the parallel fan will act as the first stage of heating when the zone requires heat. When the space temperature drops below the heating control band the parallel fan will energize. The fan will remain energized until the space temperature rises above the calculated heating setpoint.

The fan operation during unoccupied periods is same as in the occupied period. In this case the calculated heating setpoint will have been setback to the unoccupied value.

The parallel fan is disabled when the operational mode is primary heating, primary off and primary fan only. The fan is also disabled during supplemental local heating.

**Figure 10: Temperature Controlled Parallel Fan Operation**

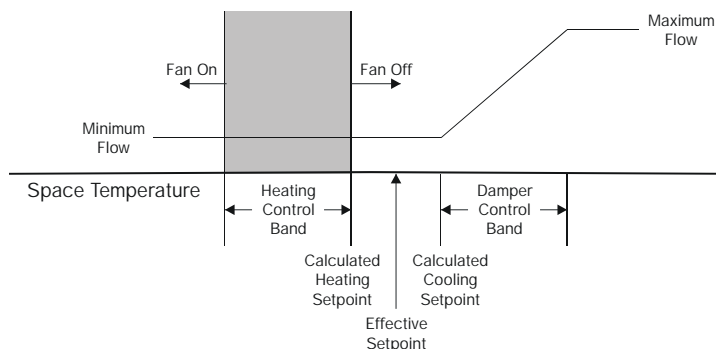

### Flow Controlled Parallel Fan Operation

During occupied periods when the operational mode is primary cooling, the parallel fan will act as the first stage of heating when the airflow drops below the fan flow setpoint. When the space temperature drops below the heating control band the parallel fan will energize. The fan will remain energized until the space temperature rises above the calculated heating setpoint.

During unoccupied periods, the fan is temperature controlled. The fan operation during unoccupied periods is same as the temperature controlled fan. In this case the calculated heating setpoint will have been setback to the unoccupied value.

The parallel fan is disabled when the operational mode is primary heating, primary off and primary fan only. The fan is also disabled during supplemental local heating.

**Figure 11: Flow Controlled Parallel Fan Operation**

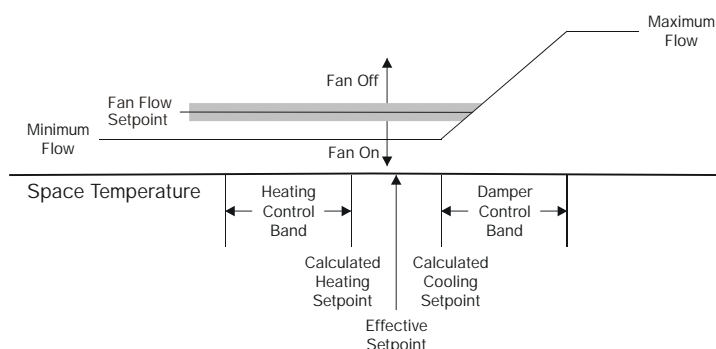

## Series Fan Operation

During occupied periods, the series fan will always run. During unoccupied periods, the series fan remains off unless there is a call for heating or cooling and the calculated flow setpoint is not zero. Since a call for zero airflow will close the damper completely, the controller will shut off the series fan if the calculated flow setpoint is zero.

During primary off and primary fan only modes, the series fan is disabled.

## Indoor Air Quality (IAQ)

The IAQ feature allows the VAV-1 to interface with the primary air source controller to maintain the quality of indoor air within the zone acceptable limits. The IAQ sensing device can be defined as local or system wide IAQ. Local IAQ is defined as a VAV-1 with an IAQ sensor attached. System wide IAQ consists of an IAQ sensor attached to the primary air source controller. In this case the IAQ would be mounted in the return air duct.

When an IAQ alarm condition is sensed by the VAV-1 in local IAQ mode, only the damper of the VAV-1 with the active alarm condition will be able to enter the IAQ mode of operation. The VAV-1 will signal the primary air source controller indicating that a local IAQ alarm condition exists in the zone. The primary air source controller will energize the supply air fan in an attempt to provide additional fresh air to the zone. After a configurable delay, the primary air source controller will open the economizer and signal the VAV-1 that IAQ mode has been entered. The VAV-1 will modulate the damper to maintain the programmed maximum airflow setpoint. When the IAQ alarm condition ceases to exist, the VAV-1 will signal the primary air source controller and resume normal control of the damper.

The VAV-1 has a temperature-reset function for IAQ alarm operation. The temperature-reset function allows the space temperature to rise above or drop below the calculated control setpoints by a configurable amount. This feature allows time for the indoor air quality to improve. During IAQ alarm operation, if the space temperature rises above or drops below the temperature-reset limit, the VAV-1 will resume normal damper control to maintain comfort within the zone. Once the space temperature brought within the calculated control setpoints and an IAQ alarm condition still exists, the VAV-1 will resume the IAQ mode of operation.

The VAV-1 has an alarm delay function that configures how long it will wait before signaling an IAQ alarm condition.

The VAV-1 can optionally participate in system wide IAQ alarm operation. In this case the primary air source controller will signal the VAV-1 indicating IAQ mode of operation is active.

## Stand Alone Mode

In this mode, the VAV-1 functions independently from the central HVAC system and is not grouped under a primary source device. The VAV-1 assumes that cool air is being provided by the central HVAC system, and provides local heating as necessary without communicating demand to any master controller.

The VAV-1 operates in stand alone mode until it is grouped under a primary source device at the LCI. To place the VAV-1 back into stand-alone mode after it has been grouped, remove it from the master controller's group, set the *Stand Alone Mode* system option to "On", and reset the controller.

## Heating Failed

The VAV-1 receives information about the state of the HVAC heating equipment from the primary air source controller. A signal will be sent to the VAV-1 when the HVAC heating has failed to turn off. To help prevent overheating of the equipment, the VAV-1 will override the calculated airflow setpoint and position the damper to maintain the maximum airflow setpoint.

## Digital Thermostat Module (DTM)

The STAT input is a bi-directional serial data link between the VAV-1 and the DTM. The space temperature value, setpoint adjustment, and occupancy override request are monitored by the DTM and sent to the VAV-1 over the serial link. The current space temperature reading, current setpoint value, control occupancy mode, fan status and override time are sent back to the thermostat. The VAV-1 periodically sends configuration information indicating valid modes, sensors, setpoints, limits and icons to the thermostat module.

The setpoint adjustment is performed using the increment and decrement buttons on the thermostat. When the increment pushbutton is pressed, the setpoint will begin incrementing. When the decrement button is pressed, the setpoint will begin decrementing. In both cases, the increment or decrement function will stop when the button is released. The adjusted setpoint will be sent to the VAV-1 through the serial interface. Once the adjustment is complete, the display will revert to the current space temperature reading. The range of the adjustment is a configuration parameter.

A pushbutton is provided on the thermostat for the occupancy extension request feature. When the button is pressed, the extension timer will be armed with the configured occupancy extension time. The request will switch the operating mode to OCCUPIED if the current mode is UNOCCUPIED and the extension timer has not expired. The occupancy extension LED on the thermostat will be on when the controller is in the extended occupancy mode. The mode will automatically switch back to UNOCCUPIED and the LED will turn off once the extension timer has expired.

The VAV-1 sends the current control mode to the thermostat. When the heating mode is enabled, the heating icon will be displayed. In the cooling mode, the cooling icon will be displayed. Neither icon will be displayed when the control is off.

The VAV-1 will automatically detect a failure of the thermostat. When the thermostat fails, the damper will close, local heating will be disabled, and the fan will turn off.

## Local Backup Schedule

A remote device on the network normally provides the current occupancy mode. A local backup schedule is provided for cases when the remote device is not available. When the VAV-1 detects that the remote device is not available, it resorts to the local backup schedule.

The schedule defines an occupied and unoccupied period within the day. The user configures the occupied and unoccupied times that are used in determining the current operating mode.

## Runtime Accumulations

The total runtime is accumulated for the local heating outputs. The runtime can be used to indicate that maintenance is required on the equipment controlled by these outputs. The runtime can also be used to calculate the energy usage of electric reheat stages. An operator or maintenance personal can reset the runtime once servicing has been performed. The runtimes are accumulated in volatile memory (RAM). Once a day they are backed up to non-volatile memory (EEPROM). When the VAV-1 is reset, the runtimes are copied from EEPROM to RAM.

## Alarm and Event Reporting

The VAV-1 will detect certain alarm conditions and reports them to the LCI. Before this can occur, the VAV-1 must have been configured by the LCI.

### Indoor Air Quality (IAQ) Alarm

The VAV-1 monitors the status of the IAQ digital input and generates an “indoor air quality alarm” when the contact closes.

### Thermostat Failure

The VAV-1 automatically detects the presence of the thermostat and monitors its status. If the thermostat fails to communicate with the VAV-1, a “thermostat failure alarm” will be generated.

### Maintenance Alarm

A VAV-1 provides programmable run limits for generating runtime maintenance alarms. When the heating runtime exceeds these limits, a maintenance alarm is sent to the LCI.

### Space Temperature Alarms

The VAV-1 generates high and low limit alarms for the space temperature. A programmable space temperature alarm limit offset is provided. The temperature limits are calculated based on the control setpoints, control band and the alarm limit offset.

$$HighLimit = CalcColingSp + ControlBand + AlarmLimitOffset$$

$$LowLimit = CalcHeatingSp \angle ControlBand \angle AlarmLimitOffset$$

When the measured space temperature exceeds the high limit, a high limit alarm is generated. When the space temperature drops below the low limit, a low limit alarm is generated. A return to normal is generated when the space temperature is between the high and low limit. The space temperature alarms are delayed by 30 minutes when the occupancy mode changes from unoccupied to occupied. This permits the space to reach the operating setpoints before generating an alarm.

### Starved Box Alarm

If the VAV-1 detects that it is not receiving sufficient airflow from the central HVAC system to meet its airflow setpoint even though the damper is at 100%, a “Starved Box Alarm” is sent to the LCI. This alarm can be disabled via the *Starved Box Alarm* system option.

## Manual Overrides

Manual override of the damper control is provided for use during installation and air balancing of the zone. The override will permit the installer/balancer to override the damper in the following manner:

1. Control flow to a user defined value
2. Fully open the damper
3. Fully close the damper
4. Control flow to the minimum value
5. Control flow to the maximum value.

## Automatic Configuration

The VAV-1 and iWorX Local Control Interface (LCI) use a self-configuring network management scheme requiring no external tools, binding, or LONWORKS knowledge. The LCI recognizes and configures the VAV-1 when the controller’s service pin is pressed. The controller’s status light flashes green until the controller is configured, and will be solid green after the controller is configured. Once the service pin has been pressed, no further action is required by the user; the controller is fully accessible to the LCI. Users may bind to SNVTs on the VAV-1 with LNS or other LONWORKS tools if they wish.

The LCI also provides network supervision of the VAV-1. The LCI periodically sends a “ping” message to the VAV-1, which elicits a response. If the response fails, an alarm is displayed on the LCI. The LCI also uses the “ping” message to refresh the occupancy mode and other system wide data.

## VAV-1 Configuration

Once the VAV-1 is properly installed and recognized by the Local Control Interface (LCI), the LCI can be used to configure the settings of the controller. This section describes the commands available on the LCI for configuration of the VAV-1, and the meanings and default values for controller parameters. For more information on using the LCI, see the *iWorX LCI User's Guide*.

### Change Setpoint

This screen displays the current setpoint. Press **Set Temp** to manually override active the effective setpoint.

### Setup

#### Heating / Cooling Settings

This screen displays the heating and cooling setpoints used by the VAV-1 controller. Use the up and down arrow keys to select a value to change, then use **-** or **+** to increase or decrease the value (or utilize use keys to directly enter the desired value). Press **Save** to save your changes or **Back** to return to the Setup screen.

**Table 1: VAV-1 Heating and Cooling Settings**

Setpoint	Range	Default	Description
Unoccupied Heating	50 to 95 °F (10 to 35 °C)	60.0°F (15.5 °C)	Heating setpoint for unoccupied time periods.
Occupied Heating	50 to 95 °F (10 to 35 °C)	70.0°F (21.1 °C)	Heating setpoint for occupied time periods.
Occupied Cooling	50 to 95 °F (10 to 35 °C)	72.0°F (22.2 °C)	Cooling setpoint for occupied time periods.
Unoccupied Cooling	50 to 95 °F (10 to 35 °C)	82.0°F (27.7 °C)	Cooling setpoint for unoccupied time periods.
Heating Control Band	0 to 10 °F (0 to 5.56 °C)	0.0 ° (Disabled)	Value to subtract from the calculated heating setpoint to form the temperature range in which local heating is enabled.
Heat Timer	0 to 65535 seconds	300 seconds	The rate at which heating stages are sequenced or the full stroke time of the valve.
Local Heating Type	Disabled, Floating Modulated Valve, 1 Stage 2 Valve, 2 Stage	Disabled	Type of local heating to be controlled by the VAV-1.

#### List All Settings

Displays all of the VAV-1's setpoints and editable settings and provides access to edit all VAV-1 parameters from a single screen.

**Table 2: All VAV-1 Settings**

Setting	Range	Default	Description
Commissioning			
- Override Mode	Off, Flow Value, Damper Fully Open, Damper Fully Closed, Damper Minimum, Damper Maximum	Off	Set to any value besides "Off" to place the VAV-1 into that override mode.
- Flow Value	0 to 5000 CFM (0 to 2360 liters/second)	0 CFM	Flow rate to use when the VAV-1 is placed in "Flow Value" override mode.

**Table 2: All VAV-1 Settings (Continued)**

Setting	Range	Default	Description
<b>Occupied Temp. Setpoints</b>			
– Occupied Cool	50 to 95 °F (10 to 35 °C)	72.0°F (22.2 °C)	Cooling setpoint for occupied time periods.
– Unoccupied Cool	50 to 95 °F (10 to 35 °C)	82.0°F (27.7 °C)	Cooling setpoint for unoccupied time periods.
– Occupied Heat	50 to 95 °F (10 to 35 °C)	70.0°F (21.1 °C)	Heating setpoint for occupied time periods.
– Unoccupied Heat	50 to 95 °F (10 to 35 °C)	60.0°F (15.5 °C)	Heating setpoint for unoccupied time periods.
Minimum Flow	0 to 5000 CFM (0 to 2360 liters/second)	100 CFM (47 liters/sec.)	Minimum desired airflow through the terminal box.
Maximum Flow	0 to 5000 CFM (0 to 2360 liters/second)	500 CFM (236 liters/sec.)	Maximum desired airflow through the terminal box.
Damper Control Band	0 to 20 °F (0 to 11.12 °C)	4 °F (2.22 °C)	Value added to calculated cooling setpoint or subtracted from the calculated heating setpoint to form the damper modulation range.
Heating Control Band	0 to 10 °F (0 to 5.56 °C)	0.0 ° (Disabled)	Value to subtract from the calculated heating setpoint to form the temperature range in which local heating is enabled.
Reheat Flow	0 to 5000 CFM (0 to 2360 liters/second)	0 CFM (0 liters/second)	Airflow setpoint used if local reheat is active.
Local Heating Type	Disabled, Floating Modulated Valve, 1 Stage 2 Valve, 2 Stage	Disabled	Type of local heating to be controlled by the VAV-1.
Heat Timer	0 to 65535 seconds	300 seconds	The rate at which heating stages are sequenced or the full stroke time of the valve.
<b>System Options<sup>a</sup></b>			
– Local IAQ Alarm?	Off, On	Off	Set to “On” to enable IAQ features using input from the local IAQ sensor. <sup>a</sup>
– Global IAQ Alarm?	Off, On	Off	Set to “On” to enable IAQ features using input from the master air handler’s IAQ sensor. <sup>a</sup>
– Supplemental Heat?	Off, On	Off	Enables supplemental heating, see “Local Heating” on page 11. <sup>a</sup>
– Reverse Damper?	Off, On	Off	Reverse direction of the damper actuator. <sup>a</sup>
– Starved Box Alarm	Off, On	On	Set to “On” to enable reporting of “Starved Box” conditions. <sup>a</sup>
– Stand Alone Mode	Off, On	On <sup>b</sup>	Set to “On” to place controller in stand alone mode regardless of grouping. <sup>a</sup>
– Auxiliary Heating Mode	Off, On	Off	Set to “On” to use auxiliary heating as first stage of heating. See “Auxiliary Heating Mode” on page 12. <sup>a</sup>

**Table 2: All VAV-1 Settings (Continued)**

Setting	Range	Default	Description
Fan Type	Disabled, Series Fan, Parallel (Temp), Parallel (Flow),	Disabled	Type of fan controlled by the VAV-1. Set to "Parallel (Temp)" if running the VAV-1 in Auxiliary Heating Mode.
Setpoint Adjust	0 to 10 °F (0 to 5.56 °C)	5.0 °F (2.78 °C)	Maximum amount of setpoint adjustment allowable from the DTM.
Occupancy Extend Time	0 to 1000 minutes	60 minutes	Allowable occupancy extension time.
K Factor	0 to 5000 CFM (0 to 2360 liters/second)	0 CFM (0 liters/second)	K factor of the terminal box in use.
IAQ Delay Time	0 to 1000 minutes	5 minutes	Delay before reporting a local IAQ alarm.
Space Temperature Reset Limit	0 to 15 °F (0.0 to 8.33 °C)	5.0 °F (2.78 °C)	Space temperature reset limit for IAQ alarm operation.
Space Temperature Alarm Limit	0 to 15 °F (0.0 to 8.33 °C)	5.0 °F (2.78 °C)	Offset subtracted from the heating control setpoint to determine the temperature below which an alarm should be generated, or added to the cooling setpoint to determine the temperature above which an alarm should be generated.
Heat Runtime Limit	0 to 65535 hours	1000 hours	Runtime limit for heating after which a maintenance alarm is generated.
Occupied Time			
– Hours	0 to 23	0	Time to begin occupied period for the local backup schedule.
– Minutes	0 to 59	0	
Unoccupied Time			
– Hours	0 to 23	0	Time to end occupied period for the local backup schedule.
– Minutes	0 to 59	0	
Fan Flow Setpoint	0 to 5000 CFM (0 to 2360 liters/second)	0 CFM	Setpoint for controlled parallel fan operation.

- a. Note that after changing any system options, the controller must be reset before these new values take effect.  
b. The VAV-1 automatically exits stand alone mode when it is grouped under a primary source device at the LCI.

## Inputs

The Inputs screen displays the current values of the VAV-1's inputs. These values cannot be changed.

**Table 3: VAV-1 Inputs**

Setting	Range	Description
Space Temperature	-22 to 122 °F (-30 to 50 °C)	The space temperature reported by the digital thermostat module.
Indoor Air Quality	Normal, Alarm	Current status of the IAQ sensor.
Discharge Temperature	-22 to 122 °F (-30 to 50 °C)	Current value of the discharge air temperature sensor

## Outputs

This screen displays the current values of the VAV-1's outputs. These values cannot be changed.

**Table 4: VAV-1 Outputs**

Setting	Range	Description
Heat Output	0.00% to 100.00%	Heat output currently being supplied to the space.
Local Reheat Output	0.00%, 50.00, or%100.00%	Current status of the reheat outputs.
Cool Output	0.00% to 100.00%	Current status of the cooling outputs.
Fan Output	0.00% or 100.00%	Current status of the fan outputs.
Box Flow Output	0 to 5000 CFM (0 to 2360 liters/second)	Current primary flow through the terminal box.

## Runtimes/Limits

This screen shows all runtime totals and runtime limits for the VAV-1. To reset a runtime total to zero, use the up and down arrows to highlight the value, and then press **Reset**. To change a value, highlight it and press **Select**.

**Table 5: VAV-1 Runtimes/Limits**

Setting	Range	Default	Description
Heating Runtime	0 to 65535 hours	N/A	Current heating runtime.
Heating Runtime Limit	0 to 65535 hours	1000 hours	Runtime limit for heating after which a maintenance alarm is generated.

## Troubleshooting

### Diagnostic LEDs

The controller has 4 LED indicators. These indicators can aid in troubleshooting equipment operation problems. The following table lists the functions of the controller's LEDs in the order they appear from left to right on the unit.

**Table 6: Controller LED Indicators.**

LED	Indication
Status	<ul style="list-style-type: none"> <li>– Solid green when running and configured by an LCI</li> <li>– Flashing green when running and NOT configured by an LCI</li> </ul>
Network	<ul style="list-style-type: none"> <li>– Yellow while the controller is transmitting data onto the FTT-10A network</li> <li>– Green when there is network activity</li> <li>– Off when there is no network activity</li> </ul>
Fault	<ul style="list-style-type: none"> <li>– Solid red when a fault condition exists</li> </ul>
Service	<ul style="list-style-type: none"> <li>– Illuminated when the service pin is pushed</li> </ul>

**Figure 12: VAV-1 Controller LEDs**

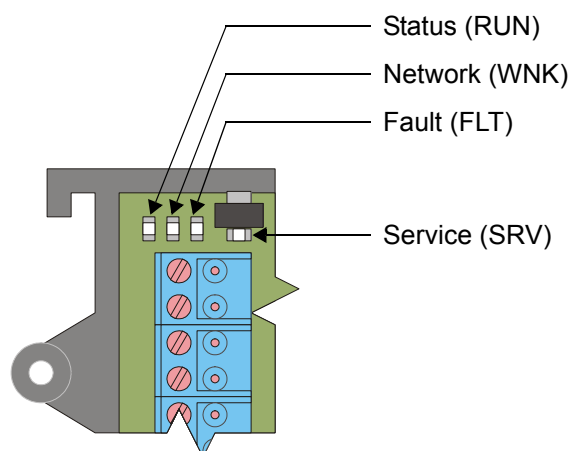

### Troubleshooting Tips

#### **Controller is not running and Status LED is not illuminated.**

No power to controller. Verify the voltage on the controller's power connector (24 VAC).

#### **How do I reset the controller?**

The controller can be reset by the LCI, or you can cycle power to the controller. Refer to the LCI documentation for more information on resetting the controller using the LCI.

#### **I am using a DTM-4 thermostat and cannot force the fan ON.**

On the VAV-1 controller, the Fan Override button is disabled. DTM-4s are not recommended for use with the VAV-1 controller.

#### **On other iWorX controllers, the status LED will turn Red when the controller has entered a fault mode that requires a reset. Are there any such modes on the VAV-1?**

Yes, but it doesn't require a reset. As with any of the controllers, if the controller detects that no DTM present, an alarm is issued, the controller enters fault mode, and the LED is turned red. However, this type of failure doesn't require a manual reset.

**Can VAV-1 controllers have independent schedules?**

Yes, each VAV-1 controller on the network can be part of a different LCI group containing a different schedule. Remember the LCI is limited to 16 groups and 16 schedules.

**What is the maximum number of VAV-1 controllers that the LCI can support?**

Since VAV-1 controllers require either a VPU-1 or MPU-1 controlling the air-handling unit, the LCI can support up to 32 VAV-1 controllers per MPU-1 and up to 60 VAV-1 controllers per VPU-1. Remember the LCI can only support a maximum of 63 controllers.

**When will the damper be controlled to the minimum flow value?**

The damper will be controlled to the minimum flow value when the space temperature is satisfied.

**Is there any provisions for an air balancer to override the VAV box damper?**

Yes, using the LCI there is a mode that an air balancer can manipulate the damper or set it to maintain a specified flow.

**My VAV boxes are not entering heating or cooling mode.**

Have the VAV-1s been grouped with an VPU-1 or MPU-1? Have you sent the grouping information to the controllers?

**My temperature and flow readings are fluctuating rapidly.**

Verify that the VAV-1 is properly grounded. There must be a wire jumper between terminals T9 and T10.

**Controller is not in stand alone mode, even though it has been ungrouped.**

The VAV-1 does not automatically re-enter stand alone mode when it is deleted from a VPU-1 or MPU-1's group. Manually place the VAV-1 in stand alone mode from the "System Options" screen of the LCI, and reset the controller.

**Controller is operating as if in stand alone mode, even though it is grouped.**

If the VAV-1 has been manually switched to stand alone mode, it does not automatically exit stand alone mode when it is added to a VPU-1 or MPU-1's group. Switch "Stand Alone Mode" to "Off" on the "System Options" screen of the LCI, and reset the controller.

**Changes to system options are not taking effect.**

To prevent inadvertent changes to the functionality of the VAV-1, the controller must be reset after any changes on the "System Options" screen of the LCI.